

# Instruments Specifications

## OR35-OR36-OR38

4 to 32 ch. Teamwork instruments



## Table of Content

---

<b>General description</b> .....	<b>3</b>
Modules .....	3
Basic hardware configuration .....	4
PC requirements .....	4
<b>Connections</b> .....	<b>4</b>
Network .....	4
Cascade .....	5
<b>Case</b> .....	<b>5</b>
Mechanicals .....	5
Power supply .....	6
<b>Environmental / Compliance with standards</b> .....	<b>7</b>
Radio frequencies sensibility .....	7
OR36 & OR38 Removable Disk .....	7
<b>Front-end</b> .....	<b>8</b>
Expander modules (XPod) .....	10
CAN BUS probe .....	11
<b>Digital computation</b> .....	<b>11</b>
Signal Processing Units .....	12
Special DSPs modules .....	12
Computation DSPs modules .....	12
<b>Notes</b> .....	<b>12</b>

## General description

The following specifications concern OR35<sub>2</sub>, OR36<sub>3</sub> & OR38<sub>3</sub> Teamwork instruments. These systems consist of OR3x hardware containing optional inputs and processing modules, a PC with an Ethernet interface, and NVGate® software with optional plug-in analyzers.

### Modules

The following tables detail the complete capacity of OR35<sub>2</sub>, OR36<sub>3</sub>, & OR38<sub>3</sub> hardware system. Optional or standard modules may fill the described slots.

#### OR35

<b>Front-end slots</b>	Dynamic and/or parametric analog inputs	2 slots of 4 universal inputs (BNC)
	Dynamic analog outputs	1 slot of 2 outputs (BNC)
	Externals sync	1 slot of 2 trigger/tachometer inputs (BNC)
	Dynamic Inputs (+2)	1 slot of 2 dynamic inputs shared with Externals sync BNCs
<b>Auxiliary slots</b>	1 slot for: TEDS	
<b>Processor slots</b>	PC, Disk, Bus interfaces	1 slot
	Clock synchronization	1 slot
	Trigger / tachometer / monitoring	1 slot of 1 ForceDSP
	Real-time Processing power	2 slots of 1 ForceDSP
<b>Miscellaneous</b>	Internal hard drive	64 GB internal SSD
	High speed serial ports	1 port for CAN Bus probe
	Remote control (power control, NVTerm)	1 RS232 cable connection (RJ11)

#### OR36

<b>Front-end slots</b>	Dynamic and/or parametric analog inputs	4 slots of 4 universal inputs (BNC)
	Dynamic analog outputs	1 slot of 2 outputs (BNC)
	Externals sync	1 slot of 2 trigger/tachometer inputs (BNC)
	Auxiliary	2 slots of 2 inputs/outputs for optional outputs, Ext. sync or DC (parametric) inputs (BNC)
<b>Auxiliary slots</b>	1 slot for: TEDS	
<b>Processor slots</b>	PC, Disk, Bus interfaces	1 slot
	Clock synchronization	1 slot
	Trigger / tachometer / monitoring	1 slot of 1 ForceDSP
	Real-time Processing power	4 slots of 1 ForceDSP
<b>Miscellaneous</b>	Internal hard drive	128 to 256 GB removable SSD with USB 3.0 port
	High speed serial ports	2 ports for CAN Bus probe
	Remote control (power control, NVTerm)	1 RS232 cable connection (RJ11)

#### OR38

<b>Front-end slots</b>	Dynamic and/or parametric analog inputs	4 slots of 8 universal inputs (BNC)
	Dynamic analog outputs	1 slot of 2 outputs (BNC)
	Externals sync	1 slot of 2 trigger/tachometer inputs (BNC)
	Auxiliary	2 slots of 2 inputs/outputs for optional outputs or Ext. sync or DC (parametric) inputs (BNC)
<b>Auxiliary slots</b>	1 slot for: TEDS	
<b>Processor slots</b>	PC, Disk, Bus interfaces	1 slot
	Clock synchronization	1 slot
	Trigger / tachometer / monitoring	1 slot of 1 ForceDSP
	Real-time Processing power	8 slots of 1 ForceDSP
<b>Miscellaneous</b>	Internal Hard drive	128 to 256 GB removable SSD with USB 3.0 port
	High speed serial ports	2 ports for CAN Bus probe
	Remote control (power control, NVTerm)	1 RS232 cable connection (RJ11)

## Basic hardware configuration

Hardware unit contains at least the following modules. All the other modules are optional.

### OR35

<b>Front end</b>	4 universal analog inputs, 2 analog outputs, 2 trigger/tachometer inputs + 2 analog dynamic inputs
<b>Processors</b>	1 interface board (Ethernet, CAN, Disk, USB) 1 Clock synchronization module 1 master ForceDSP module for Trigger / tachometer / monitoring. 1 ForceDSP computation module
<b>Disk</b>	64 GB internal SSD

### OR36

<b>Front end</b>	4 universal analog inputs, 2 analog outputs, 2 trigger/tachometer inputs
<b>Processors</b>	1 interface board (Ethernet, CAN, Disk, USB) 1 Clock synchronization module 1 master ForceDSP module for Trigger / tachometer / monitoring. 1 ForceDSP computation module
<b>Disk</b>	128 GB removable SSD with USB 3.0 port

### OR38

<b>Front-end</b>	8 universal analog inputs, 2 analog outputs, 2 trigger/tachometer inputs
<b>Processors</b>	1 interface board (Ethernet, CAN, Disk, USB) 1 Clock synchronization module 1 master ForceDSP module for Trigger / tachometer / monitoring. 1 ForceDSP computation module
<b>Disk</b>	128 GB removable SSD with USB 3.0 port

## PC requirements

<b>Minimum</b>	1 GB <sup>1</sup> of RAM / 250 MB free on HD + storage for measurements and signals / 1024 x 768 display
<b>Recommended (for laptop)</b>	<b>Dual/quad core processor</b> (e.g.: Intel Core i5) / > 2.5 GHz / <b>4 GB</b> of RAM / GPU / 1368 x 768 display / 1 GB free on HD + storage for signals
<b>Recommended (for desktop)</b>	<b>Quad core processor</b> (e.g.: Intel Core i7) / <b>6 GB</b> of RAM / GPU / <b>1920 x 1080 display</b> / 1 GB free on SSD + storage for signals
<b>Connections</b>	Type: <b>Ethernet 1000 BASE-T</b> , 1 Gb/s : Connector: <b>RJ45</b> For removable disk: <b>USB 3.0</b> / For dongle key: <b>USB 2.0</b>
<b>Operating systems</b>	Windows 7 / Windows 8 & 8.1 / Windows 10 / <b>MS Office</b> : 32 bits only

## Connections

### Network

OR35<sub>2</sub>, OR36<sub>3</sub> & OR38<sub>3</sub> can operate over multiple network configurations.

<b>Connection to PC</b>	<b>Ethernet 1 Gb/s</b> / > 100 m / Cat 5E
<b>Security</b>	Support <b>SSH tunneling connections</b>
<b>IP management</b>	TCP/IP / The instrument can be <b>DHCP server</b> (non-authoritative)
<b>Supported Networks</b>	<b>WAN</b> (Internet) / <b>LAN</b> (Company) / <b>Wi-Fi</b> (wireless)

1) Waterfall depth depends on available memory.

## Cascade

OR35<sub>2</sub>, OR36<sub>3</sub> & OR38<sub>3</sub> can be cascaded flexibly.

### Synoptic

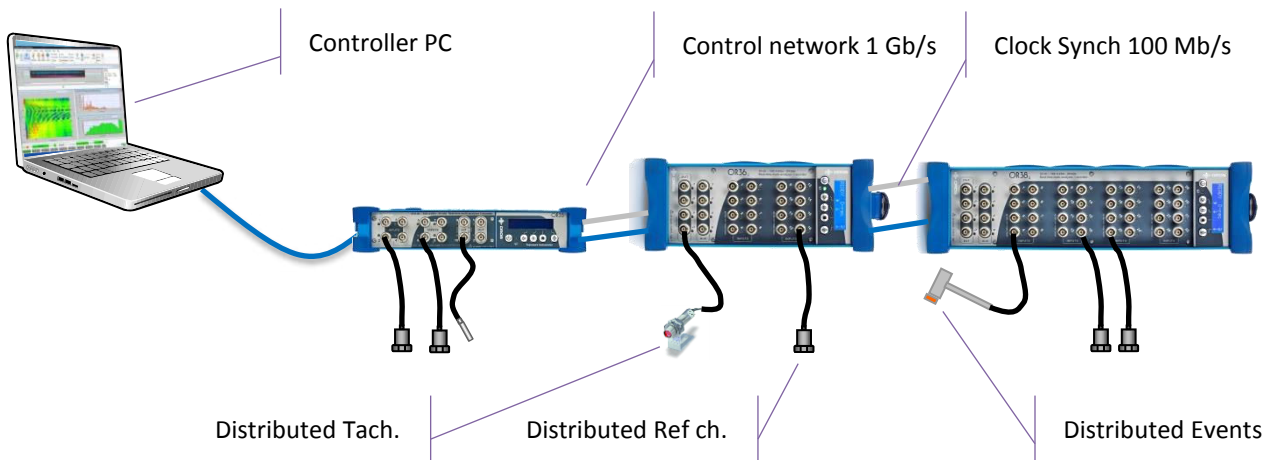

### Specifications

<b>Configuration</b>	<b>Switchless daisy-chain / 30+ cascaded analyzers / Mixed analyzer's type</b>
<b>Connections</b>	NVGate: Ethernet <b>1Gb/s</b> / Clock sync & Reference distribution : Ethernet <b>100 Mb/s</b>
<b>Cables</b>	> <b>100 m</b> per connection / Variable lengths / Cat 5E
<b>Master/Slave</b>	Undifferentiated analyzers' type
<b>Accuracy</b>	<b>Phase : &gt; ±0.2° @ 20 kHz / &gt; 8 ns @ 51.2 kS/s / Amplitude: &gt; ±0.02 dB</b>
<b>Synch. protocol</b>	<b>IEEE 1588.2 Precision Time Protocol / SyncE</b> (synchronous Ethernet) - No phase shift
<b>IP management</b>	<b>Automatic IP</b> check and resolution at NVGate start / <b>DHCP server</b> (non-authoritative)

## Case

### Mechanicals

#### OR35

<b>Weight</b>	<b>3 kg (6.6 lb)</b>	
<b>Dimensions</b>	Case (w.h.d)	<b>303 mm x 52 mm x 236 mm</b> (11 15/16" in x 2 1/16" in x 9 9/32" in)
	Overall (w.h.d)	<b>310 mm x 58 mm x 245 mm</b> (12 7/32" in x 2 9/32" in x 9 21/32" in)

#### OR36

<b>Weight</b>	<b>5.6 kg to 6.1 kg (12.3 lb to 13.4 lb)</b>	
<b>Dimensions</b>	Case (w.h.d)	<b>102 mm x 260 mm x 311 mm</b> (4 1/32" in x 1 1/4" in x 12 25/32" in)
	Overall (w.h.d)	<b>114 mm x 280 mm x 325 mm</b> (4 1/2" in x 11 1/32" in x 12 25/32" in)

#### OR38

<b>Weight</b>	<b>7.9 kg to 8.8 kg (17.4 lb to 19.4 lb)</b>	
<b>Dimensions</b>	Case (w.h.d)	<b>102 mm x 380 mm x 311 mm</b> (4 1/32" in x 15" in x 12 25/32" in)
	Overall (w.h.d)	<b>114 mm x 400 mm x 325 mm</b> (4 1/2" in x 15 3/4" in x 12 25/32" in)

## Power supply

### OR35

<b>Power</b>	<b>&lt; 30 VA</b>	
<b>External AC Power supply</b>	Voltage	<b>100 to 240 VAC / 1.7 A max</b>
	Frequency	<b>50/60 Hz</b>
<b>DCin</b>	Range	<b>10 V to 28 V</b>
	Overload protection	Absolute maximum < <b>40 V</b> / > <b>31 V</b> poles are disconnected
<b>Battery</b>	Type	Built-in <b>89 Wh Li-ion</b> 8 modules
	Autonomy	<b>3 h</b>
	safety	Certified under <b>UN38.3</b> and <b>IEC 62133</b> regulations
	Charge time	<b>3 h</b> (typical)
	Charge conditions	DC power supply > 12 V

### OR36

<b>Power</b>	<b>&lt; 60 VA</b>	
<b>External AC Power supply</b>	Voltage	<b>100 to 240 VAC / 1.7 A max</b>
	Frequency	<b>50/60 Hz</b>
<b>DCin</b>	Range	<b>12 V<sup>2</sup> to 28 V</b>
	Overload protection	<b>31 V</b> (over this voltage DC poles are short-circuited)
<b>Battery</b>	Type	<b>NiMh</b> 11 modules (no memory effect)
	Autonomy	<b>2 h</b>
	Charge time	<b>2 h 30 min</b> (typical)
	Charge conditions	DC power supply > 18 V

### OR38

<b>Power</b>	<b>&lt; 100 VA</b>	
<b>External AC Power supply</b>	Voltage	<b>100 to 240 VAC / 2.0 A max</b>
	Frequency	<b>50/60 Hz</b>
<b>DCin</b>	Range	<b>15 V<sup>3</sup> to 28 V</b>
	Overload protection	<b>31 V</b> (over this voltage DC poles are short-circuited)
<b>Battery</b>	Type	<b>NiMh</b> 17 modules (no memory effect)
	Autonomy	<b>2 h</b>
	Charge time	<b>3 h</b> (typical)
	Charge conditions	DC power supply > 24 V

2) DC power voltage > 17 V will discard the battery

3) DC power voltage > 22 V will discard the battery

## Environmental / Compliance with standards

CE/CB/FCC	Indicates compliance with EMC Directive <b>89/336/EEC</b> and Low Voltage Directive <b>73/23/EEC</b>	
Safety	EN 61010-1	Safety requirements for electrical equipment for measurement, control and laboratory use.
	Over-voltage Cat.	<b>II</b> (Local level mains, appliance, and portable equipment)
	Pollution Degree	<b>2</b> : Do not operate in environments where pollutants may be present.
EMC Emission	EN 50081-1	Generic emission standard: Residential, commercial and light industry.
	EN 50081-2	Generic emission standard: Industrial environment.
	IEC 61326-1	Electrical equipment for measurement control and laboratory use EMC requirements.
	CISPR 22	Radio disturbance characteristics of information technology equipment: 22 Class B limits.
	FCC Rules	Complies with the limits for a Class B digital device.
EMC Immunity	EN 50082-1	Generic immunity standard: Residential, commercial and light industry.
	IEC 61326-1	Electrical equipment for measurement control and laboratory use EMC requirements.
	EN 50082-2	Generic immunity standard: Residential, commercial and light industry.
	Linear input response range on interference	max slew rate on input: <b>5 V/ μs</b>
Materials	ROHS	<b>2011/65/EU</b>
	WEEE	<b>2002/96/CE - 2003/108/CE - 2012/19/EU</b>
Temperature	OR35, OR36 Operating	<b>-20°C<sup>4</sup> to 50°C</b> (-4°F to 122°F)
	OR38 Operating	<b>-20°C<sup>4</sup> to 45°C</b> (-4°F to 113°F)
	Storage	<b>-20°C to 65°C</b> (-4°F to 149°F)
	Absolute maximum rating <sup>ii</sup>	<b>-35°C to 70°C</b> (-31°F to 158°F)
Humidity	Max <b>80 % RH</b> at 40°C non condensing	
Shocks	Complies with <b>IEC 68-2-27</b>	
	Operating	<b>100 m/s<sup>2</sup></b> (11 ms, ½ sine) and <b>700 m/s<sup>2</sup></b> (3 ms, ½ sine)
	Storage	<b>200 m/s<sup>2</sup></b> (11 ms, ½ sine) and <b>1 000 m/s<sup>2</sup></b> (3 ms, ½ sine)
	Absolute maximum rating <sup>ii</sup>	<b>1 000 m/s<sup>2</sup></b> (3 ms, ½ sine)
Vibrations	Complies with <b>IEC 68-2-6</b>	
	Operating	<b>10 m/s<sup>2</sup>, 5-500 Hz, 5mm</b>
	Storage	<b>25 m/s<sup>2</sup>, 5-500 Hz, 5mm</b>
	Absolute maximum rating <sup>ii</sup>	<b>30 m/s<sup>2</sup>, 5-500 Hz, 5mm</b>
Enclosure	OR35	<b>IP 40</b>
	OR36, OR38	<b>IP 42</b>

### Radio frequencies sensibility

	Input measured with 50 Ω terminator
Radiated RF: 80-1000 MHz, 80% AM 1 kHz, 10 V/m	< 20 μV
Conducted RF: 0.15-80 MHz, 80% AM 1 kHz, 10 V	< 100 μV
Magnetic field: 30 A/m, 50 Hz	< 2 μV

### OR36 & OR38 Removable Disk

Performances	Type	<b>1.8" - SSD - 128 GB or 256 GB - MLC NAND Flash Memory</b>
	Shock	<b>15 000 m/s<sup>2</sup></b> - 0.5 ms ½ sine
	Vibrations	<b>50 m/s<sup>2</sup></b> - 10 to 2 kHz
	Throughput	<b>32 inputs + 6 aux. @20 kHz BW – 10h 40min</b> gap free
	MTBF	<b>2 x 10<sup>6</sup> hours</b>
Case	Case (w.h.d)	<b>83 mm x 20 mm x 97 mm</b> (3.24 in x 0.78 in x 3.79 in)
	weight	<b>0.200 kg</b> (0.55 lb)
Connection	Into the analyzer	<b>SATA - 1.5 Gb/s</b> sustained read/write
	To the PC	<b>USB 3.0 - 200 Mb/s</b> sustained read
Power supply	On PC	<b>USB</b> powered
	On analyzer	<b>Internal</b> power supply

4) Requires a warmup (power on + run NVGate) which last 1 min per 1 Celsius degree below zero.

## Front-end

Each front end slot of the OR35 (4 BNC + 2 BNC), OR36 (4 BNC) and the OR38 (8 BNC) can be occupied by one of the following inputs type:

- Universal inputs
- Dynamic inputs
- Parametric inputs

### Universal inputs

The universal inputs gather both dynamics and parametric input in the same board and connector. The universal inputs are necessary to support the XPod signal conditioners. The type of use of the universal inputs is selectable by software (NVGate) during the analyzer operations.

The universal inputs fulfill all the performances, precision and operability of each specific input type.

### Dynamic inputs

<b>Sampling</b>	Sampling frequencies (Additional decimators allow analysis bandwidth down to 0.8 Hz)	<b>102.4 kHz, 65.536 kHz, 51.2 kHz, 37.768 kHz, 25.6 kHz, 16.384 kHz, 12.8 kHz, 8.192 kHz, 6.4 kHz, 5.12 kHz, 4.096 kHz, 3.2 kHz, 2.048 kHz</b>
	Converters	One <b>24 bit sigma-delta ADC</b> for each input
	Frequency relative precision	<b><math>0.5 \cdot 10^{-4}</math></b> (typical $1 \cdot 10^{-5}$ )
	Synchronization	All inputs synchronized on the same sampling clock
<b>Anti-aliasing filter</b>	Type	Over-sampled digital filters
	Slope	<b>&gt; 400 dB/octave</b>
	Pass band ripple	<b>&lt; <math>\pm 0.005</math> dB</b>
	Rejection of parasites bands	<b>&gt; 100 dB</b> (@ frequency > 0.57 x FS)
	Effective bandwidth	<b>0.45 x FS</b> (ex: 23.4 kHz @ 51.2 kS/s)
<b>Range (peak)</b>	With amplifier (included)	<b><math>\pm 100</math> mV, <math>\pm 300</math> mV, <math>\pm 1</math> V</b>
	Direct	<b><math>\pm 10</math> V</b>
	With attenuator (included)	<b><math>\pm 40</math> V</b>
<b>Absolute accuracy</b>	Resolution	<b>24 bits</b> (144 dB)
	All input ranges at 1 kHz	<b><math>\pm 0.05</math> dB</b> (typical $\pm 0.015$ dB)
	Temperature variability	<b>&lt; 0.002 dB / 10 °C</b>
<b>DC offset</b>	$\pm 100$ mV, $\pm 300$ mV and $\pm 1$ V ranges	<b>&lt; <math>\pm 100</math> <math>\mu</math>V</b>
	$\pm 10$ V range	<b>&lt; <math>\pm 1</math> mV</b>
	$\pm 40$ V range	<b>&lt; <math>\pm 2</math> mV</b>
<b>Frequency flatness and phase response<sup>5</sup></b>	<i>Inside one front-end</i>	
	$\pm 10$ V range, DC to 20 kHz	<b>&lt; <math>\pm 0.02</math> dB / &lt; <math>\pm 0.02</math> °</b>
	$\pm 10$ V range, 20 kHz to 40 kHz	<b>&lt; <math>\pm 0.05</math> dB / &lt; <math>\pm 0.05</math> °</b>
	$\pm 0.1$ V, $\pm 0.3$ V, $\pm 1$ V ranges, DC - 20 kHz	<b>&lt; <math>\pm 0.02</math> dB / &lt; <math>\pm 0.1</math> °</b>
	$\pm 0.1$ V, $\pm 0.3$ V, $\pm 1$ V ranges, 20 kHz - 40 kHz	<b>&lt; <math>\pm 0.1</math> dB / &lt; <math>\pm 0.5</math> °</b>
	$\pm 40$ V range, DC - 20 kHz	<b>&lt; <math>\pm 0.1</math> dB / &lt; <math>\pm 0.4</math> °</b>
	$\pm 40$ V range, 20 kHz - 40 kHz	<b>&lt; <math>\pm 0.1</math> dB / &lt; <math>\pm 0.8</math> °</b>
<i>Mixed front-ends</i>		
$\pm 10$ V range, DC to 20 kHz	<b>&lt; <math>\pm 0.02</math> dB / &lt; <math>\pm 0.2</math> °</b>	
<b>Cross-talk</b>	<i>Between N (N is odd) and N+1 inputs:</i>	
	@ 1 kHz: < <b>-120 dB</b> , @ 20 kHz: < <b>-96 dB</b> , @ 40 kHz: < <b>-90 dB</b>	
	<i>Between any inputs excluding: N (N is odd) and N+1 inputs:</i>	
@ 1 kHz: < <b>-140 dB</b> , @ 20 kHz: < <b>-114 dB</b> , @ 40 kHz: < <b>-108 dB</b>		
<b>Signal to noise ratio</b>	<i>With 50 <math>\Omega</math> terminators:</i>	
	$\pm 10$ V range, 40 kHz bandwidth: > <b>100 dB</b> , spurious lines < <b>-115 dB</b> of full scale	
	$\pm 10$ V range, 20 kHz bandwidth: > <b>104 dB</b> , spurious lines < <b>-125 dB</b> of full scale	
<b>Input noise</b>	<i>With 50 <math>\Omega</math> terminators:</i>	
	Thermal input noise	<b>20nV/<math>\sqrt</math>Hz</b>
	$\pm 100$ mV and $\pm 300$ mV ranges	20 kHz BW < <b>3.5 <math>\mu</math>V rms</b> , 40 kHz BW: < <b>5 <math>\mu</math>V rms</b>
	$\pm 1$ V range	20 kHz BW < <b>5.4 <math>\mu</math>V rms</b> , 40 kHz BW: < <b>8.5 <math>\mu</math>V rms</b>
$\pm 10$ V range	20 kHz BW < <b>44 <math>\mu</math>V rms</b> , 40 kHz BW: < <b>70 <math>\mu</math>V rms</b>	

5) Includes channel to channel match with different ranges

### Dynamic inputs (continued)

<b>Impedance</b>		<b>1 MΩ ±1 %, &lt; 100 pF</b>
<b>Protection</b>	Overvoltage	<b>±60 V peak without damage - On any input<sup>ii</sup></b>
<b>Dynamic</b>	Spectral domain	<b>&gt; 140 dB<sup>6</sup></b>
<b>Coupling</b>	AC	Cut-off frequency <b>0.35 Hz ±10%</b> (analog filter)
	DC	
	ICP	<b>2 mA or 4 mA</b> power supply with AC coupling (±10%)
	ICP + TEDS	ICP + reverse current on TEDS reading operations
	GND	Shortcut to ground - <b>Automatic current limitation</b> to 50 mA
<b>Floating</b>	Coupling	<b>AC or DC / All ranges / overall voltage &lt; ±40 V</b>
	Common mode voltage (all ranges)	Max: <b>±12 V</b>
<b>TEDS</b>	Standards	<b>IEEE 1451.4 2001 revision 1</b>
	Supported templates	Accelerometer/Force meter ( <b>25</b> ) Microphones ( <b>27, 28 and 29</b> )

### Parametric (DC) inputs

The following parametric inputs can be added to the standard OR36<sub>3</sub> or OR38<sub>3</sub> hardware configuration as follows:

- On the **auxiliary slots** by set of 2 inputs (max 4)<sup>7</sup>
- On the **OR36** as replacement of 4 dynamics inputs (max 12)
- On the **OR38** as replacement of 8 dynamics inputs (max 24)

The following specifications apply to the universal inputs.

<b>Sampling</b>	Bandwidth / Sampling	<b>-3 dB @ 3.5 Hz</b> Independent from dynamic sampling clock
	Converters	One <b>24 bit sigma-delta ADC</b> for each input
<b>Range (peak)</b>	Direct	<b>±10 V</b>
	With attenuator (included)	<b>±40 V</b>
<b>Frequencies rejection</b>	Notch filters frequencies	<b>50 Hz &amp; 60 Hz @ ±1%</b>
	Rejection	<b>&gt; 120 dB</b>
<b>Amplitude</b>	Effective resolution	<b>22 bits</b> (out of noise)
	Linearity	Typ. <b>0.0003 %</b> of input range peak
	Gain drift	<b>20 ppm</b> of input range peak/°C typ.
<b>Offset</b>	Offset	±10 V range: < <b>±1 mV</b> / ±40 V range: < <b>±2 mV</b>
	Offset drift	±10 V range: < <b>40 μV/°C</b> / ±40 V range: < <b>160 μV/°C</b>
<b>Impedance</b>		<b>1 MΩ, 5 nF</b> typ.
<b>Protection</b>	On any input <sup>ii</sup>	<b>±60 V</b> peak
<b>Input Noise</b>	<i>With 50 Ω terminators, excepted ±40 V range:</i>	
	Input noise	< <b>4 μV</b> rms in 0.1 to 2 Hz BW – Typ <b>2 μV</b> rms
	Max. Deviation	< <b>6 μV</b> peak

### Dynamic outputs

<b>Sampling</b>	Converters	One <b>24 bit DAC</b> for each output
	Synchronization	Same sampling clock as the dynamic inputs
<b>Range</b>	Direct	<b>±10 V peak</b>
	With attenuator (included)	<b>±1 V peak</b>
	Clipping	<b>User selectable</b> in the output range
	Digital gain	From <b>10<sup>-5</sup> to 10<sup>3</sup></b>
<b>Absolute accuracy</b>	Resolution	<b>24 bits</b> (144 dB)
	All output ranges at 1 kHz	<b>±0.05 dB</b>
	Temperature variability	<b>&lt; 0.1 dB / 10 °C</b>
<b>Frequency response</b>	<i>Variation relative to 0 dB @ 1kHz</i>	
	All ranges, at 10 kHz	<b>&lt; ±0.05 dB</b>
	All ranges, at 20 kHz	<b>&lt; ±0.15 dB</b>
	All ranges, at 40 kHz	<b>&lt; ±0.8 dB</b>

6) 25601 lines / 30 sec. averaging

7) DC inputs on auxiliary slots features 16 bit dedicated converters, see previous instrument specifications(M002-19-4) for details

### Dynamic outputs (continued)

Noise floor level	10 V range, 20 kHz bandwidth	-110 dB of full scale, spurious lines < -125 dB of full scale
	10 V range, 40 kHz bandwidth	-105 dB of full scale, spurious lines < -125 dB of full scale
	1 V range, 20 kHz bandwidth	-99 dB of full scale, spurious lines < -110 dB of full scale
	1 V range, 40 kHz bandwidth	-94 dB of full scale, spurious lines < -110 dB of full scale
Impedance	User selectable	50 Ω, 600 Ω or Grounded
Current	Max	±10 mA
Protection	Sum of injected + generated voltages	±15 V peak, On any output <sup>ii</sup> Permanent short circuit supported
Total harmonic distortion	THD @ 1 kHz	< 0.002% or -94dB at 20 kHz BW
	THD @ 5 kHz	< 0.005% or -86dB at 20 kHz BW
Cross-talk	Output 0 dBV to 50 Ω terminated input	Lower than measurable noise

### External sync

Sampling	Frequencies	64 times over-sampling of the current input sampling (up to 6.4 MHz)
	Converters	High speed voltage comparator and time counter
Ranges (peak)		±300 mV, ±1 V, ±3 V, ±10 V, ±40 V
Resolution	Amplitude accuracy	±1% of range
Setting	Hysteresis	1% (of input range) to input range
	Hold off	0 s to 500 s
	Slope	Rise or fall
	Hardwired pre-divider	1 to 255
Accuracy	Time resolution	> 160 ns (0.06° at 1 kHz and 1.2° at 20 kHz)
Pulse rate	Max	375 kpulse/s
Coupling	AC	Cut-off frequency 0.35 Hz ±10% (analog filter)
	DC	
Impedance		1 MΩ, < 100 pF
Protection	on any external sync <sup>ii</sup>	±60 V peak without damage

### Expander modules (XPod)

With the universal inputs the OR35<sub>2</sub>, OR36<sub>3</sub> and OR38<sub>3</sub> can receive signal conditioning modules called XPod. Different Xpod types are available.

#### Wheatstone bridge XPod

Connectors	Type	Sub-D9 – Female
Bridges	Mounting	Full, Half and quarter
	½ bridge completion resistors	2 * 10 kΩ - 0.1% - 10 ppm
	¼ bridge completion resistors	120 Ω or 350 Ω - 0.1% - 25 ppm
	Excitation voltages	0 to 10 V
	Excitation currents	0 to 4 V: < 30 mA - 4 V to 10 V: < 12 mA
	Sensing	Negative and positive probes
Amplifiers	Type	Differential - DC capable
	Gains	10 or 100
	Error	< 0.01 dB
Inputs	Ranges	±100 mV - ±1 V
	Common mode voltage	±7 V without limiting differential input
	Impedance	1 MΩ
	Noise floor levels (100 Hz to 20 kHz)	Gain 100: 2 μVrms - Gain 10: 4 μVrms
DC offset	Temperature drift	1 μV/°C
	Compensation resolution	3 % of present offset
Protection	Overvoltage	Device on: max ±30 V - device off: max ±15 V

### Temperature XPod

The temperature XPod operates on the universal or parametric inputs. The XPod support thermocouple and RTDS conditioning, cold point compensation and linearization. Amplified signal are injected in the analyzer on the ±10 V range.

Connectors	Type	Mini Thermocouple/RTD type
	Pins	<b>3 polarized pin</b> - spring-loaded - compatible with 2 point plugs
	Material	Glass filled thermoplastic - White body
Thermocouples	<b>Type J</b>	<b>-210 °C to +1 100 °C</b> - Yellow LED
	<b>Type K</b>	<b>-200 °C to +1 300 °C</b> - Green LED
	<b>Type T</b>	<b>-200 °C to +390 °C</b> - Brown LED
	<b>Type N<sup>8</sup></b>	<b>-200 °C to +1 200 °C</b> - Pink LED
	<b>Type E</b>	<b>-200 °C to +800 °C</b> - Purple LED
	Cold compensation	Integrated - 2 sensors - user on/off
RTDS	Absolute temperature error	> -150 °C : ± <b>0.9°C</b> / < -150 °C : ±( <b>0.4°C + 0.1%</b> of MT <sup>9</sup> )
	PT 100	<b>-190 °C to +880 °C*</b> - Blue LED
	PT 1000	<b>-190 °C to +880 °C*</b> - Grey LED
	Absolute temperature error	±( <b>0.4°C + 0.3%</b> of MT <sup>9</sup> )
	Wires	3 wires connections
	Current	PT100: <b>500 µA to 4 mA</b> - PT1000: <b>500 µA to 1 mA</b>

\* Calibrated up to +800 °C

### CAN BUS probe

The CAN bus probe is connected to the OR35<sub>2</sub>, OR36<sub>3</sub> and OR38<sub>3</sub> via the high speed serial ports. It offers a passive CAN bus listener with the following specifications.

<b>Type</b>	Standards	<b>CAN 2.0A &amp; CAN 2.0B</b> / Compliant with <b>J1939 protocol</b>
	Speed	<b>125 kb/s to 500 Mb/s</b>
<b>Probe</b>	Probe	<b>High Z / Analyzer or bus powered</b>
	Connectors	CAN : <b>Sub-D 15</b> / Analyzer: <b>High speed serial port</b> (1,5 m)
<b>Capacity</b>	Channels	<b>24 @ 10 Hz</b> refresh rate / <b>Synchronous</b> with analyzer inputs

### Digital computation

The following table details the calculation needs (SPUs) for each analysis plug-in of NVGate software.

<b>Narrow band analysis (FFT)</b>	Real-time FFT analysis with;
	<b>401 lines</b> (for 801, 1601,3201, 6401 lines, multiply requested SPU respectively by 1.25, 1.5, 2, 3)
	<b>20 kHz</b> bandwidth (Requested SPU are proportional to bandwidth)
	<b>0% overlap</b> 1 channel processing requires <b>1 SPU</b>
<b>Synchronous order analysis</b>	Real-time order spectrum analysis (re-sampled time signal) with:
	Any duration of visualization, any averaging
	<b>20 kHz</b> bandwidth (Requested SPU are proportional to bandwidth) 1 channel processing requires <b>3 SPUs</b>
<b>Time Domain analysis</b>	Real-time time domain monitor and statistical analysis with:
	Simultaneous time view and statistical extraction. Any duration of visualization, any averaging
	<b>20 kHz</b> bandwidth (Requested SPU are proportional to bandwidth) 1 channel processing requires <b>3 SPU</b>
<b>1/n Octave</b>	Real-time filter based 1/n octave analysis with:
	<b>1/3rd</b> octave (for 1/12 <sup>th</sup> and 1/24 <sup>th</sup> octave multiply requested SPU respectively by 2 and 4)
	<b>20 kHz</b> bandwidth (Requested SPU are proportional to bandwidth) 1 channel processing requires <b>3 SPUs</b>
<b>Recorder</b>	Gap free recording with:
	<b>51.2 kHz</b> sampling rate gap free recording
	1 channel processing requires: <b>0.66 SPU</b>

8) Add 0.1°C to absolute temperature error

9) MT is Measured Temperature

## Signal Processing Units

SPU (Signal Processing Units): the previous table gives the characteristics of each analysis mode and the associated SPU consumption. For multi-analysis purpose, add the corresponding SPUs of each mode used simultaneously and increase the sum by 10%. "Real-time" means that the analysis speed is faster than the input rate and does not miss any sample.

## Special DSPs modules

The following DSPs are always integrated in OR35, OR36 & OR38 hardware.

<b>Master DSP module</b>	Monitor computations	<b>FFT 401 lines</b> (max 4 Channels)
	Time domain detectors	<b>DC, Max, Min, RMS, Kurtosis</b> (on the monitor Channels)
	Special	Auxiliary inputs, Events, Tachs, Torsion, Generators

## Computation DSPs modules

The following computation DSP modules are optional

### ForceDSP

<b>Type</b>	Sample size	<b>32 bit floating</b>
	Computation words	<b>32/40 bit</b>
	Internal memory	<b>16 MSample</b>
<b>Power</b>	Computation capability	<b>Up to 48<sup>10</sup> SPU / DSP module</b>
<b>Input sharing</b>	Inputs per DSP	<b>8 max</b>

### Number of DSPs/unit

<b>Minimum</b>	<b>1</b> Computation DSP module	<b>Up to 48<sup>10</sup> SPU</b>
<b>OR35 Max.</b>	<b>2</b> Computation DSP modules	<b>Up to 96<sup>10</sup> SPU</b>
<b>OR36 Max.</b>	<b>4</b> Computation DSP modules	<b>Up to 192<sup>10</sup> SPU</b>
<b>OR38 Max.</b>	<b>8</b> Computation DSP modules	<b>Up to 384<sup>10</sup> SPU</b>

## Notes

The previous specifications describe all the guaranteed capacities and performances of the instrument and are applicable to an OR35<sub>2</sub>-10, OR36<sub>3</sub>-16 or OR38<sub>3</sub>-32 hardware powered for more than 15 minutes at a stabilized room temperature of 23°C ±5°C and calibrated since less than one year.

The adapted control software NVGate is described separately.

<sup>i</sup> Prepared for future use: the related specifications or options are in development.

<sup>ii</sup> Exceeding absolute maximum ratings damages the system and voids guarantee.

Specifications not binding; OROS reserves its right to change these specifications without notice.

<sup>10</sup>: SPUs are variable in *ForceDSPs*. Consult [customer.care@oros.com](mailto:customer.care@oros.com) for advanced real-time analysis

# OROS, Leadership through Innovation

## About Us

OROS designs and manufactures noise and vibration testing systems (instruments and software) for more than 30 years, meeting the requirements and expectations of automotive, aerospace, marine energy & process, manufacturing and automation industries.

## Our Philosophy

Reliability and efficiency are our ambition everyday. We know you require the same for your measurement instruments: comprehensive solutions providing performance and assurance, designed to fit the challenges of your demanding world.

## Our Emphasis

Continuously paying attention to your needs, OROS collaborates with a network of proven scientific affiliates to offer the latest of the technology, always based on innovation.

## Worldwide Presence

OROS products are marketed in more than 35 countries, through our authorized network of representatives, offices and accredited maintenance centers.

## Want to know more?

<b>OROS headquarters</b>	<b>OROS Americas Inc.</b>	<b>OROS French Sales Office</b>	<b>OROS GmbH</b>	<b>OROS China</b>
Tel: +33.476.90.62.36	Tel: +1.616.202.7349	Tel: +33.169.91.43.00	Tel: +49.261.133.96.50	Tel: +86.10.59892134
info@oros.com www.oros.com	sales@oros.com www.oros.com	info@oros.fr www.oros.fr	info@oros-deutschland.com www.oros-deutschland.com	info@oroschina.com www.oroschina.com

