

TECHNICAL MANUAL



VS1

10067 Vibration sensor powered by energy harvester



INTRODUCTION.....	4
PACKAGE CONTENTS.....	4
SETTINGS.....	5
1. Sample Rate:.....	6
2. Sample Length:.....	6
3. Sampling Period:.....	6
4. Health Data Time Interval:.....	6
OPERATION.....	7
POWER MODES.....	7
1. Standby mode:.....	7
2. Shelf mode:.....	7
3. Reset:.....	7
INSTALLATION.....	8
Harvester:.....	8
TROUBLESHOOTING.....	8
VS1.....	8
FIRMWARE UPDATES.....	9
PRODUCT CARE.....	9
General use:.....	9
Cleaning:.....	9
SUPPORT, WARRANTY & RMA ASSISTANCE.....	9
RECYCLING.....	9
VS1 TECHNICAL SPECIFICATIONS.....	10
Power supply:.....	10
Vibration required for continuous operation:.....	10
Power consumption:.....	10
Enclosure material:.....	10
Ingress protection:.....	10
Typical weight w. pot magnets:.....	11
Dimensions: (excluding mounting accessories.).....	11
Dimensions: (w. pot magnets.).....	11
Operating Temperature:.....	11
Storage Temperature:.....	11
Relative humidity:.....	11
Mounting interface:.....	11
Radio communication:.....	11
Acceleration measurements:.....	12
Temperature sensor measurement accuracy:.....	12
Edge data storage:.....	12
Time synchronization offset:.....	12
Expected product lifetime:.....	12
Accelerometer position:.....	12

TESTING STANDARDS & COMPLIANCE	13
Vibration Testing.....	13
Environmental Testing.....	13
Corrosion Resistance.....	13
Humidity & Temperature Cycling.....	13
Vibration Measurement.....	13
Ingress Protection (IP) Ratings.....	13
CONTACT	14
Manufacturer:.....	14

INTRODUCTION

The **VS1 (10067)** is a harvester-powered sensor designed for vibrating screens that wirelessly transmits captured measurement data. It utilizes the vibrating screen's movement to generate the energy required for data measurement and transmission, eliminating the need for cables or battery replacements.

The VS1 is designed to work with the TR1 (10064) or TR1-USB (10078) transceivers, utilizing the 2.4GHz spectrum for communication.

PACKAGE CONTENTS

Name:	Part no:
VS1 Vibration sensor powered by energy harvester	10067
Anti slip mounting guide	20332

SETTINGS

VS1 measures, calculates, collects, and transmits the following data:

Raw Vibration Data:

VS1 captures and transmits snippets of raw acceleration data (g) from the X, Y, and Z axes at user defined sample rates and intervals.

Aggregated Data Calculation:

VS1 captures and processes vibration data locally, computing aggregated values that are transmitted every second.

- RMS acceleration. X,Y,Z axis
- Maximum recorded acc. X,Y,Z axis
- Root mean square amplitude of acceleration. X,Y,Z axis
- Peak amplitude of acceleration. X,Y,Z axis
- Root mean square amplitude of velocity. X,Y,Z axis
- Peak amplitude of velocity. X,Y,Z axis
- Peak-to-peak amplitude of displacement. X,Y,Z axis
- Planar stroke calculated with method A. X,Y,Z axis
- Planar stroke calculated with method B. X,Y,Z axis
- Frequency of the highest spectral peak. X,Y,Z axis
- Crest factor of acceleration. X,Y,Z axis

Health Monitoring:

VS1 provides updates of the current status, including operational health and connectivity at user defined intervals. The following data is collected.

- Temperature (°C)
- RSSI (dBm)
- Voltage (mV)
- Harvesting voltage (mV)

Depending on the operational setup, users can choose from various approaches to configure the VS1 sensors.

- **Loqui API:** An API for the Anura gateway's condition monitoring system.
- **Vibreshark:** A local PC application designed for service-oriented use cases.
- **SDK:** A Python-based toolkit that enables users to develop applications for communicating with the VS1.

The VS1 offers the user access to a range of customizable operational settings.

1. Sample Rate:

Set the sample rate for VS1 (`base_sample_rate`) by choosing one of the following fixed values:

- 512 Hz
- 1024 Hz
- 2048 Hz
- 4096 Hz
- 8192 Hz
- 16384 Hz

2. Sample Length:

Calculate the length of each sample (`snippet_num_samples`) using the following formula:

$$\text{base_sample_rate} \times \text{duration_in_seconds} = \text{snippet_num_samples}$$

For example, at a base sample rate of 1024 Hz for 3 seconds:

$$1024 \text{ Hz} \times 3 \text{ seconds} = 3072 \text{ samples}$$

3. Sampling Period:

Set the sampling period by defining (`snippet_interval_ms`) time in milliseconds.

- `snippet_interval_ms` = 60000 ms (samples are taken every minute)

4. Health Data Time Interval:

Set the health interval by defining (`health_interval_ms`) time in milliseconds.

- `health_interval_ms` = 60000 ms (health data is collected every minute)

Consult with ReVibe to determine the optimal setup for maximizing the system's output.

OPERATION

The VS1 sensor is designed for permanent installation and long-term use, utilizing the vibrating screen's kinetic motion as its power source. If extended downtime is anticipated, activate shelf mode to protect the battery cell.



POWER MODES

1. Activated mode:

1. Insert a ballpoint pen into the small recessed hole near the top magnet.
2. Press gently and hold for 3 seconds or until the LED turns green. (If VS1 is discharged it will blink RED rapidly to indicate low charge)
3. Once the LED is green, the unit is powered on and ready for measurements.
4. The LED will blink green to indicate that the sensor is active and recording movement.

2. Deactivated mode:

Coming from activated mode.

1. Insert a ballpoint pen into the small recessed hole near the top magnet.
2. Press gently and hold until the LED starts blinking red, then release.
3. The LED will blink red to confirm the sensor has entered shelf mode.

3. Reset:

1. Insert a ballpoint pen into the small recessed hole near the top magnet.
2. Press lightly once. The LED will turn on (green) for 1 second to indicate a reset.
3. The unit will then reset and resume operation.

INSTALLATION

VS1 attaches to the vibrating screen via powerful neodymium magnets. To further ensure the sensor's installation position use the provided rubber anti-slip guide (20322).

Harvester:

VS1 is equipped with an energy harvester and a rechargeable battery power cell. It is delivered pre-charged, with a maximum charge capacity of 4.2V. VS1 will function until the power cell discharges to 2.9V. Once this threshold is reached, VS1 will automatically activate shelf mode to protect the battery cell.

IMPORTANT! To ensure correct operation of the energy harvesting mechanism, the vibration pattern of the machine must be taken into account when choosing mounting orientation of the sensor. The sensor must be mounted so that the projected component of the machine's vibration in the indicated harvesting direction fulfills the minimum requirements for vibrations (cf. Vibration required for continuous operation on page 12)

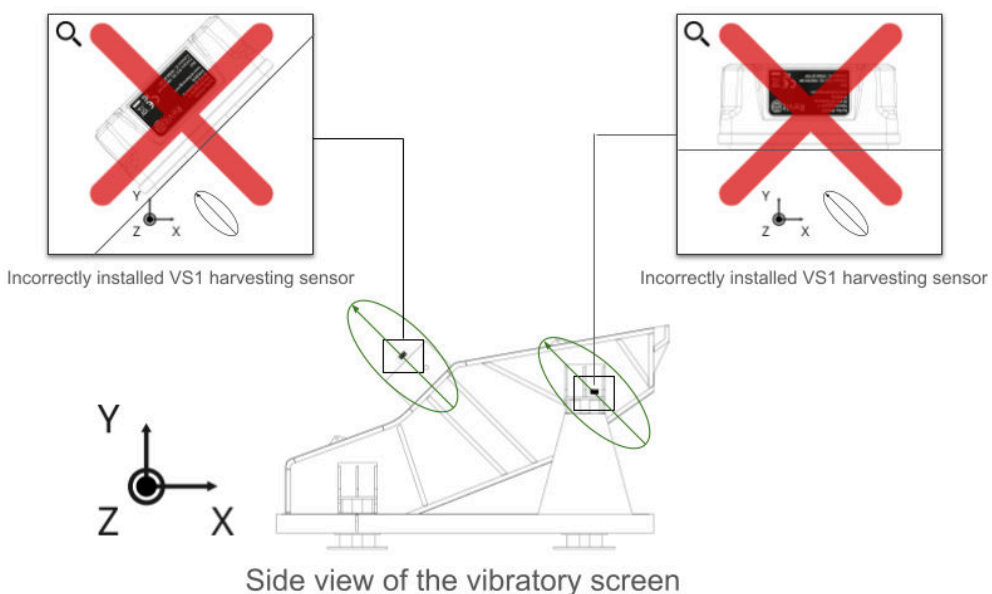
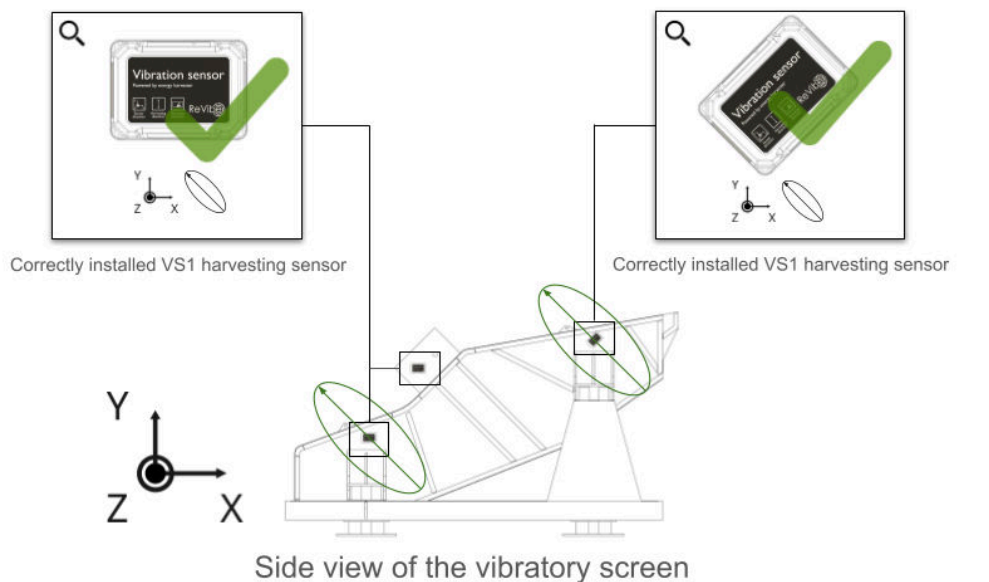

Radio transmission

Install VS1 units with consideration for optimal radio transmission.
Maintain an unobstructed line of sight to the transceivers.

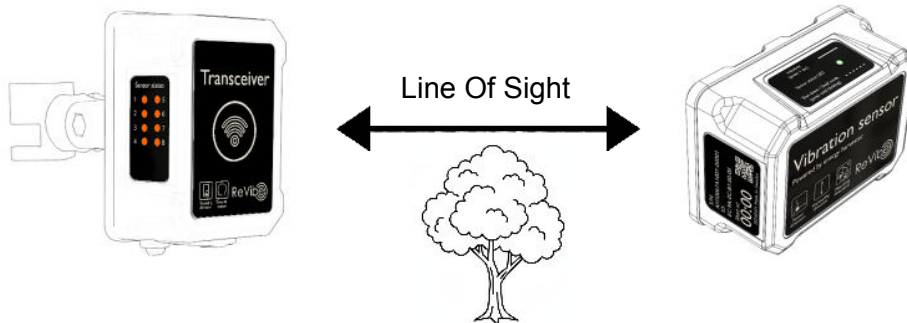

Do not mount the VS1 behind steel mesh, as this will cause significant signal attenuation.

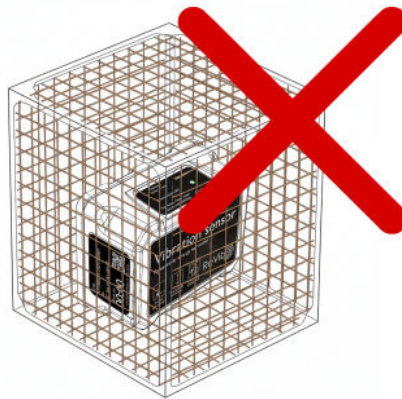

TROUBLESHOOTING

VS1

If the VS1 fails to connect to TR1 when it is installed on a machine known to provide sufficient kinetic energy for the harvesting to function (see harvesting section). Please check the following.

FIRMWARE UPDATES

The VS1 supports over-the-air upgrades using BLE, allowing users to update its firmware through the API or SDK.

PRODUCT CARE

To ensure the longevity and optimal performance of VS1, please follow these care instructions:

General use:

Do not drop, throw, or subject the product to excessive force, as this could damage the plastic casing, aluminum plate, or internal components.

Cleaning:

Use a soft, damp cloth to gently clean the plastic casing and aluminum bottom plate. Avoid abrasive materials or harsh cleaning agents, as they may scratch the surfaces or damage the finish.

SUPPORT, WARRANTY & RMA ASSISTANCE

For help with product support, warranty claims, or initiating an RMA (Return Merchandise Authorization), our website provides all the resources needed.

<https://revibeenergy.com/>

RECYCLING

Disposal of Electrical and Electronic Equipment

This product is marked with the crossed-out wheellie bin symbol to indicate that it must not be disposed of as general household waste. Instead, it should be taken to an appropriate collection point for recycling electrical and electronic equipment. Proper disposal helps prevent potential harm to the environment and human health and promotes the sustainable reuse of materials.

For more detailed information on disposal and recycling, please contact your local authorities or the retailer where the product was purchased.

VS1 TECHNICAL SPECIFICATIONS

Power supply:

Patented Electromagnetic generator.
Working frequency span:
10-22Hz (600-1320RPM) @ $\geq 1.5g_{RMS}$.
Nominal rechargeable energy storage 1.32 Wh.

Vibration required for continuous operation:

Acceleration required for continuous operation

Body sensor configuration: Sampling rate 1kHz, duration: 3 seconds, interval: 5 minutes, Running 24/7day

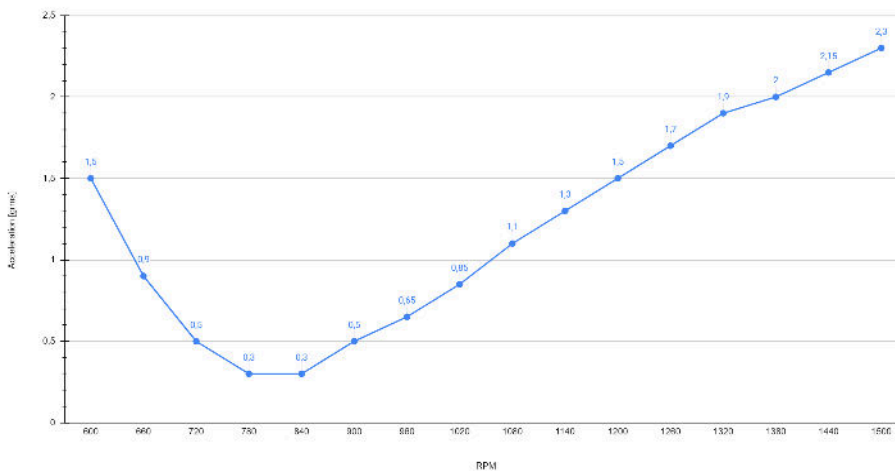

Power consumption:

Sampling rate 1024Hz, duration: 3 seconds, interval: 5 minutes
~8 mW

Sampling rate 8192Hz, duration: 5 seconds, interval: 5 minutes
~10 mW

Stand-by
<1 mW

Shelf mode
~4 μ W

Enclosure material:

Bottom plate: Anodized aluminum alloy, "Orange".
Casing: PA6, Black.

Ingress protection:

IP67

Typical weight w. pot magnets:

750g.

Dimensions: (excluding mounting accessories.)

135x98x60 (height x width x depth)

Dimensions: (w. pot magnets.)

135x98x64 (height x width x depth)

Operating Temperature:

-40°C to +80°C

Storage Temperature:

0°C to +45°C (-40°F to +140°F)

Relative humidity:

0 to 95%, non-condensing

Mounting interface:

3x Pot magnets / Universal AMPS 4xM5 hole pattern, 30x38mm.

Radio communication:

Tx Power:

0 dBm

Rx Sensitivity:

-98 dBm

Data Rates:

Up to 1 Mbps

Frequency:

2.400 to 2.483 GHz

Antenna Gain:

typ. 6dBi

Acceleration measurements:

3 Axis MEMS accelerometer
TDK InvenSense IIM-42352

Range
 $\pm 16g$

Sampling rate
Selectable: 256, 512, 1024, 2048, 4096, 8192, 16384.

Accelerometer measurement range
XY-plane: dc to 4kHz (± 3 dB point)
Z-axis dc to 1.6kHz (± 3 dB point)

Temperature sensor measurement accuracy:

Typ. ± 0.5 °C -40°C to 125°C
Typ. ± 0.25 °C, 0°C to +65°C

Edge data storage:

Non persistent 64Mbit RAM.

Time synchronization offset:

Typ. <5 us

Expected product lifetime:

>5 years

Accelerometer position:

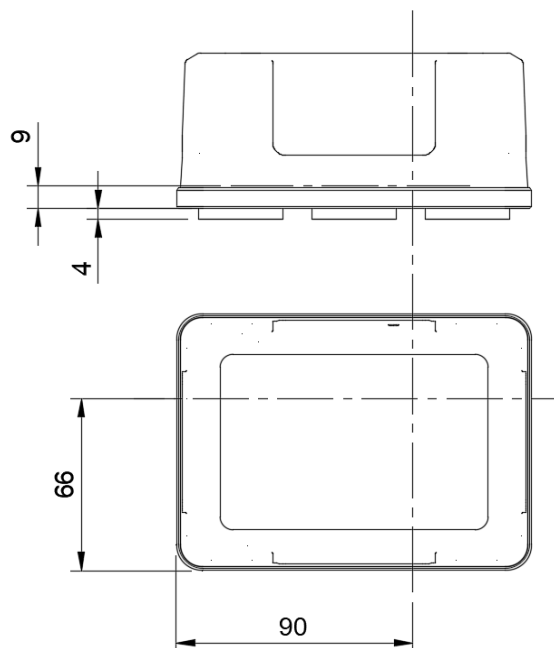

TESTING STANDARDS & COMPLIANCE

VS1 (10067) has successfully met all following international standards.

Vibration Testing

IEC 60068-2-6 – Assessed the product's mechanical robustness under sinusoidal vibration conditions, ensuring structural integrity during transport and operation.

Environmental Testing

IEC 60068-2-1 / IEC 60068-2-2 – Verified the product's ability to withstand extreme temperatures:

- **IEC 60068-2-1:** Cold test to confirm functionality at low temperatures.
- **IEC 60068-2-2:** Dry heat test to ensure performance in high-temperature environments.

Corrosion Resistance

ISO 21207:2015 – Simulated harsh environmental conditions through cyclic corrosion tests, evaluating long-term durability.

Humidity & Temperature Cycling

IEC 60068-2-30 – Exposed the product to alternating high humidity and temperature variations to assess reliability in humid conditions.

Vibration Measurement

ISO 16063-21:2003 – Ensured precise vibration response measurement using vibration transducers, verifying compliance with accuracy standards.

Ingress Protection (IP) Ratings

IEC 60529 – IP67 – Evaluated the product's resistance to dust and water:

- **IP67:** Verified resistance to full immersion in water (up to 1m for 30 minutes).

CONTACT

Manufacturer:

Revibe Energy AB
Mölnsdalsvägen 95
412 63 Göteborg
Sweden
+46 (0) 31 24 23 22
www.revibeenergy.com

