

**FLUKE®**

**Reliability**

# VIBREX®

## Installation and Operation

**db** PRÜFTECHNIK

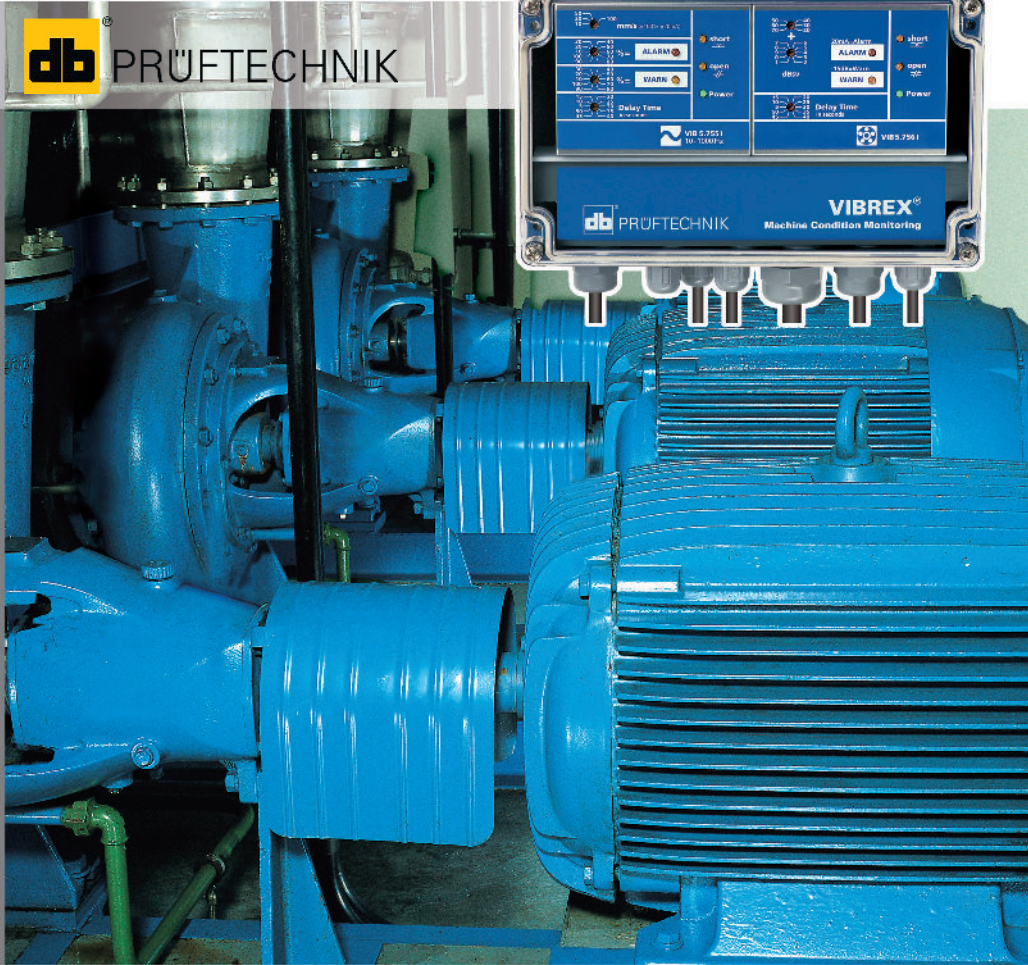



# **VIBREX**

## **Installation and operation**

Edition September 2017  
Order number VIB 9.610G

## Contents

Foreword .....	4
Safety notes .....	5
What is VIBREX? .....	6
How VIBREX works.....	7
Vibration monitoring.....	8
Special versions for special machines.....	9
Anti-friction bearing monitoring.....	10
Included items and assembly.....	12
VIBREX with mV output.....	13
Installing VIBREX .....	14
Location.....	14
Cable length.....	14
A. VIBREX housing.....	15
B1. Sensor connection to machine .....	16
B2. Sensor mounting notes (Bearing monitoring)..	18
3. Measure in the load zone .....	18
C1. Coaxial cable connection to VIBREX .....	19
C2. -- Content has been deleted .....	20
C3. Triaxial cable connection to VIBREX.....	21
D. Warning and alarm outputs.....	24
E. Analog current output (4-20 mA).....	25
F. Power supply .....	26
G. Final check .....	26
Adjusting VIBREX .....	27
Vibration monitoring .....	27
A. Vibration module adjustment.....	28
B. Gearboxes and low-speed machines .....	29
Anti-friction bearing monitoring.....	31
Bearing module adjustment .....	32
Conversion of output current level [mA] to shock pulse value [dBsv] .....	34

---

External signal measurement .....	35
Troubleshooting .....	37
Changing modules.....	38
Appendix .....	39
Connection terminals .....	39
Technical data .....	40
Dimensions.....	42
Measurement record .....	43
VIBREX modules: Application examples .....	46

© Fluke Corporation; all rights reserved

Both this manual and the product it describes are copyrighted. All rights belong to the publisher. The manual may not be copied, reproduced, translated or made accessible to a third party in any form, neither in its entirety nor as an excerpt.

No liability may be claimed against the publisher regarding the product described in this manual. The publisher assumes no liability for accuracy of the manual contents. Furthermore, under no circumstances may the publisher be held liable for direct or indirect damage of any kind resulting from use of the product or the manual, even if the publisher has expressly indicated the potential for occurrence of such damage.

The publisher assumes no liability for any product defects. This warranty and liability limitation applies to all distributors and sales partners as well.

The trademarks mentioned in this manual are generally noted as such and are the property of their owners. Lack of such designation does not imply, however, that names are not protected by trademark laws.

## Foreword

Congratulations on your decision to entrust VIBREX with monitoring your machines. This instrument gives you a reliable system for preventing unexpected machine failure: VIBREX monitors the most important machine operating condition parameters continuously and warns you immediately whenever measurements climb beyond acceptable limits.

Moreover, VIBREX offers several further advantages:

### Installation

VIBREX is delivered pre-configured so that you only have to mount it and make cable connections.

### Commissioning

Commissioning involves primarily the setting of alarm and warning limits.

### Design

The modular design of VIBREX allows combined monitoring of both machine vibration and anti-friction bearing condition. Both parameters can be measured either independently (i.e. using 2 channels) or over a single cable (1-channel) using only one sensor.

### Long signal distances

The current line drive amplifier contained in the sensor allows signal conduction over distances up to 500 meters / 1640 feet with practically no signal loss.

### 4-20 mA output

The signal level can be tapped directly from the unit itself or via an external PLS/PCS for evaluation and display.

### Alarm shutoff

VIBREX not only monitors your machines, but also takes action when alarm conditions arise: set it either to shut off the machine via an existing process control system or to notify operating personnel via signal devices.

### mV output

Each module can be equipped with a 10mV/g output. This can be used to analyze the measured signal or to check the function of the sensor.

### Intrinsic safety (option)

Intrinsically safe transducers and safety barriers are optionally available.

## Safety notes

### Intended use

VIBREX is designed for continuous vibration monitoring of machines which operate at constant speed and under constant load conditions.

VIBREX is not, however, suitable for monitoring machines whose operating condition and bearing load characteristics are influenced by greatly fluctuating load or speed control systems. PRÜFTECHNIK assumes no liability for damage due to use for purposes other than those defined above.

### Safety

Machines must be properly grounded prior to VIBREX installation and operation.

Installation, commissioning, maintenance and repairs may be performed only by properly trained personnel.

VIBREX must not be operated with its housing open.

Only original spare parts and accessories may be used.

Any changes made to the system without prior express consent of PRÜFTECHNIK shall render the manufacturer free of any liability obligation whatsoever.

The procedures described in this manual regarding warning and alarm tolerance settings apply, in their experience, to the vast majority of machines. In special cases, however, alternative setting values may be required; PRÜFTECHNIK cannot assume responsibility for the accuracy of such values.

### Symbols

Danger of improper operation/improper procedure: failure to observe can result in damage to the instrument or to the monitored machine.



Important notes and practical tips regarding operation.



## What is VIBREX?

VIBREX is a compact 2-channel vibration measuring instrument for permanent monitoring of rotating equipment. Its modular design allows optimal adaptation to the specific machine characteristics at hand. The condition parameters of 'vibration severity (ISO 10816-3)' and 'Anti-friction bearing condition' can be measured at one or two locations. Moreover, VIBREX is also ideal for monitoring the special signal characteristics of gearboxes and low-speed machines.

Combined bearing/vibration monitoring with a single dual-function sensor (1-channel operation)

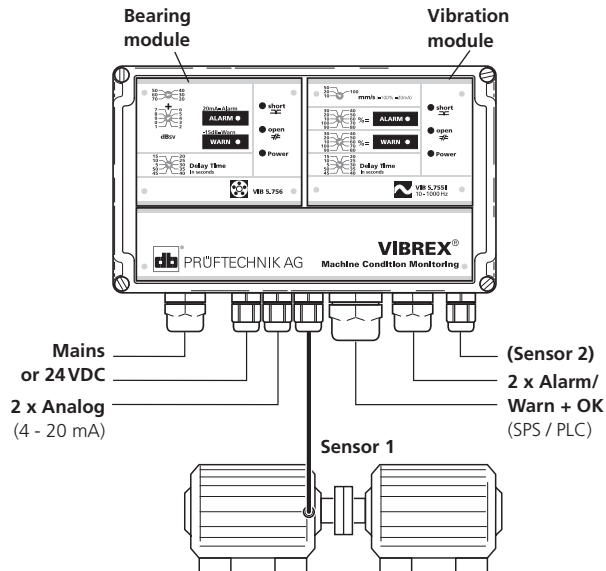

The measuring and evaluating modules can be combined as desired and used for one-channel or two-channel operation. Besides the configuration shown above (vibration/bearing condition, one channel), many other combinations are possible to suit specialized machine requirements through use of modules for gearboxes or low-speed machines.

### How VIBREX works

VIBREX processes the incoming machine signals and compares them with the limits settings. If the signal level exceeds the allowable limit, the corresponding ALARM/WARN LEDs illuminate on the front panel. At the same time, following a preset delay, a relay is activated to issue a warning or alarm signal to a connected PLC/PCS system or a signal device (buzzer, blinker etc.). The relay activates only when the signal remains constant above the limit.

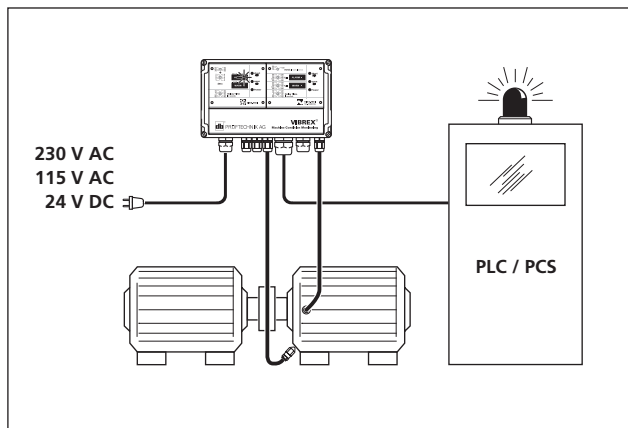

Each VIBREX module is provided with its own analog output (4-20 mA) for external measurement and evaluation of signal levels.

The self-diagnostic feature of VIBREX ensures recognition of a short circuit at the sensor, an open circuit along the signal path or a power outage. These occurrences are indicated by module LED's marked 'short' and 'open' and cause the 'OK relay' to activate accordingly (see pages 9,11 24).

VIBREX is connected directly to the mains (115V/230V AC), or a 24V DC power supply may be used instead. The 'power' LED indicates that the unit is currently powered and ready for operation.

## Vibration monitoring

The vibration module has four rotary switches used to set the monitoring parameters.

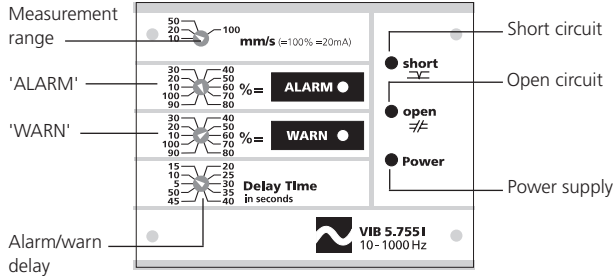

### Measurement range limit

The uppermost switch sets the measurement range limit and determines the maximum signal level for the analog output.

Example:       if max. range = 50 mm/s, then  
                           20 mA = 50 mm/s and  
                           4 mA = 0 mm/s

The current level is output in direct proportion to the measured signal value, which allows simple conversion of intermediate values (see page 28).

### Alarm/warning

The alarm and warning limits are set using the two middle switches ('ALARM', 'WARN'). Both limit values can be set in steps of 10% referenced to the maximum range setting described above.

100% warning level = max. measurement range  
 100% alarm level = max. measurement range

**OK relay**

The OK relay normally issues messages for both warnings and sensor errors (including power outage). If, however, this relay is to be used exclusively for system monitoring, the warning limit should be set to exceed the alarm limit. The relay then can no longer trigger warnings and reacts only to sensor faults and power outage.

**Note****Delay time**

The lower switch, 'Delay Time', allows you to set a short waiting period between the initial detection of alarm/warning violation and output of the corresponding signal: the violation must be detected for this duration before the alarm/warning is issued. This feature is useful to avoid false alarms due to transient signal elevations, for example, when the machine is switched on.

It does not, however, affect the behavior of the indicator LED's, which always react to warning/alarm conditions after 1 to 2 seconds.

**Special versions for special machines**

Special VIBREX modules are available for evaluating vibration level of certain machine types (see also page 46):

**Example applications**

- Low-speed machines: > 60 RPM
- Gearboxes
- Refiner
- Vibro mixer

## Anti-friction bearing monitoring

The anti-friction bearing module evaluates high-frequency shock pulse signals to determine the operating condition of the bearing.

### Alarm/warning

The two upper switches are used to set the alarm value with-in a range of 20 dBsv to 79 dBsv. The upper switch changes this value in steps of 10 dBsv, while the lower switch of the two sets it to the nearest 1 dBsv.

The alarm value also determines the maximum signal level for the analog current output (4-20mA). If the alarm value is set e.g. to 50 dBsv, then the analog output delivers 20 mA when 50 dBsv is measured and 4 mA when 0 dBsv is measured.



Note

Intermediate values can be converted from mA to dBsv as directed on page 34.

The warning level cannot be set separately for this module; it is fixed at 15 dBsv below the alarm limit.

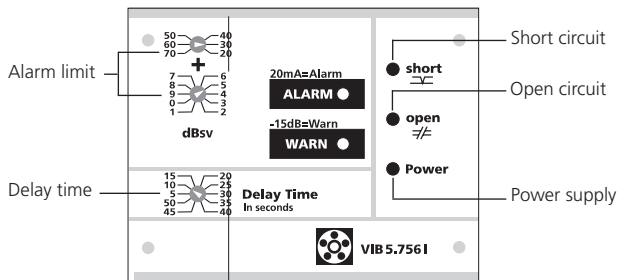

### Delay time

The lower switch, 'Delay Time', allows you to set a short waiting period between detection of alarm/warning violation and output of the corresponding signal: the violation must be detected for this duration before the alarm/warning is issued. This feature is useful to avoid false alarms due to transient signal elevations, for example, when the machine is switched on. It does not, however, affect the behavior of the indicator LED's, which always react to warning/alarm conditions after 1 to 2 seconds.

**OK relay for warning/sensor faults**

The OK relay normally issues messages for both warnings and sensor errors (including power outage). If, however, this relay is to be used exclusively for system monitoring, the wire jumper on the back of the module must be severed (page 38). The relay then can no longer trigger warnings and reacts only to sensor faults and power outage.

**Note**

Rear view

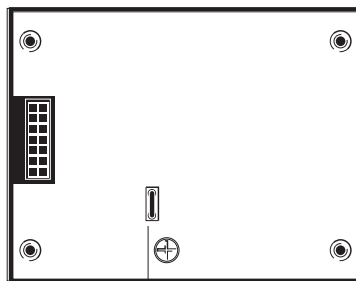

Wire jumper

**Included items and assembly**

\* VIB 5.761 I ... VIB 5.766 I

Packages are delivered fully assembled. Optional modules are delivered alongside the VIBREX basic unit and must be assembled as follows before installation:

- Remove the transparent housing cover from the VIBREX basic unit.
- Take the module out of the packaging and carefully insert it into the basic unit.



Ensure that the contact pins are not bent or otherwise damaged when inserting the module.

\*\* 'Pure' or 'combined' vibration/roller bearing condition monitoring

Which slot is used for which module depends on the number of measurement locations (1 or 2) and the operating mode\*\*.

The following applies:

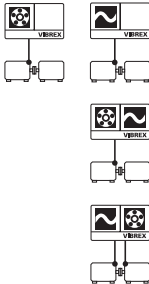

Monitoring for one location with one module:  
Select slot for left module.

Combined monitoring for one location:  
Roller bearing = left module, vibration = right module

Combined monitoring for two locations:  
Vibration = left module, roller bearing = right module

Slot for ... left module      ... right module

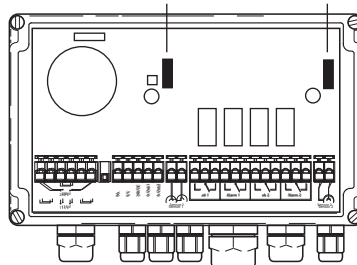

- Screw the module tightly in place and insert the second module or the blank module.
- Replace the housing cover on the basic unit.

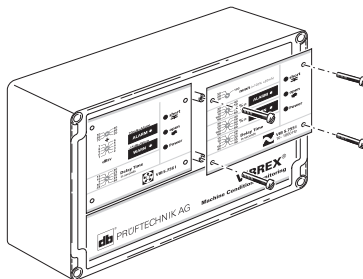

### VIBREX with mV output

Before you insert the modules of the special series into the basic unit, check the connection for the mV output on the main board. Upon delivery, the mV outputs for the vibration modules are connected - i.e. blue connector on 'VIB' plug.

If you insert one or two modules for roller bearing monitoring, connect the corresponding connector to the 'SIM' plug:

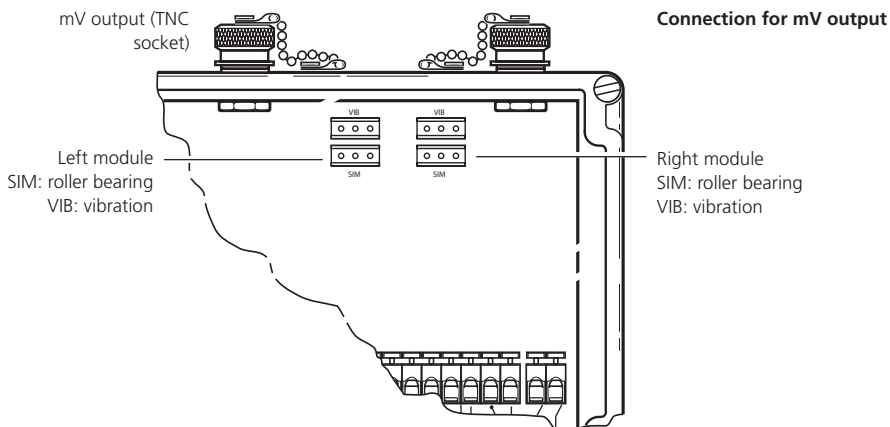

## Installing VIBREX



Machines must be properly grounded according to guidelines stated in IEC Standard 64(CO) 172 to 194 prior to VIBREX installation and operation.

### Location

VIBREX should be mounted on a sturdy, vibration-free wall or directly on the machine housing. When installing the units on machines with vibration severities  $v_{rms} > 10\text{mm/s}$  (10Hz - 1 kHz), suitable vibration dampers must be used, such as are contained in the mounting set (VIB 5.751 SET).

### Cable length

Please note the following cable specifications depending upon the desired type of measurement and cable routing.

Current-LineDrive accelerometers (e.g. VIB 6.122R):

Application	Cable length	
Bearing monitoring	< 3 m < 10 ft.	3 - 300 m 10 ft. - 1000 ft.
Vibration monitoring <sup>1</sup>	< 50 m < 160 ft.	50 - 500 m 160 ft. - 1600 ft.
Cable type (x length in m)	RG 58 (VIB 90005-x) <sup>2</sup>	triaxial (VIB 90080-x) <sup>2</sup>

<sup>1</sup> Vibration velocity and vibration acceleration.

<sup>2</sup> -x: Cable length in meters



The information specified under 'Bearing monitoring' applies to combined bearing/vibration monitoring as well.

## A. VIBREX housing

1. Mark the mounting hole locations according to the dimensions shown on page 42.
2. Drill the mounting holes.
  - Wall mounting: hole diameter 6mm, mounting plug size 6, screw size 4-5.
  - Machine mounting: Tap M4 thread for vibration dampers and screw the dampers onto the machine housing.
3. Remove the transparent housing lid.
4. Fasten VIBREX to the wall or to the machine housing.

### Wall mounting

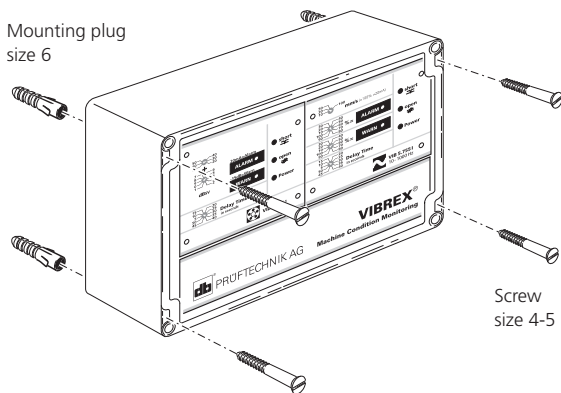

### Machine mounting

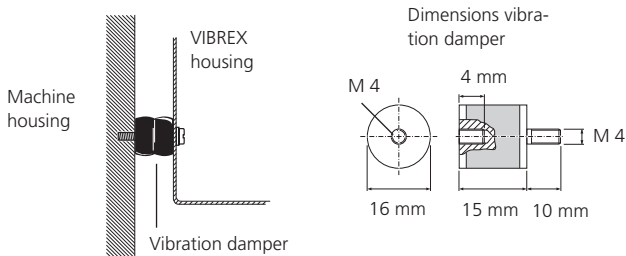

### B1. Sensor connection to machine

0. Measurement location selection:

- i. Bearing monitoring: mount sensor within load zone.

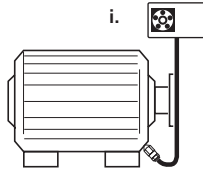

- ii. Vibration monitoring: mount sensor horizontally (or in primary direction of vibration).

- iii. Bearing/vibration monitoring, one channel: mount sensor horizontally and radially or below 45° (see i.).

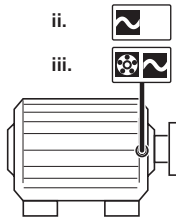

- 1. Mount the sensor according to the following instructions.



**Note**

Additional information on installing the sensors can be found in the corresponding operating manual (VIB 9.831).

## PRÜFTECHNIK accelerometers

Industrial accelerometer for threaded mounting, M8 thread

Order no.: VIB 6.122R / VIB 6.127



### Mounting instructions for VIB6.12x

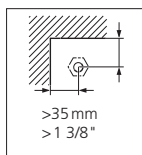

Select position

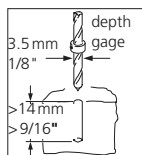

Bore pilot hole

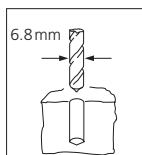

Bore out hole

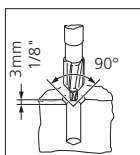

90° countersink

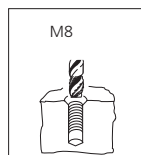

Tap thread/blow out shavings

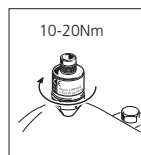

Mount sensor

## B2. Sensor mounting notes (Bearing monitoring)

The following rules should be observed when mounting sensors in order to ensure proper signal transmission.

### 1. Shortest, most direct signal path possible

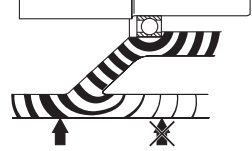

### 2. Only one material interface

High-frequency shock pulse signals in particular are severely weakened by material interfaces and bends in the signal path.

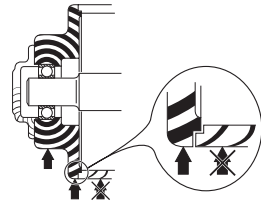

### 3. Measure in the load zone

The load zone is generally located within the lower half of the bearing housing, where the weight of the supported machine part acts. For some machines, however, such as the belt-driven fan pictured in b) above, the major force acts on the upper portion of the bearing housing. Here the belt tends to pull the drive wheel end of the motor toward the fan shaft (loading the upper portion of the corresponding motor bearing) while forcing the other end of the motor downward (loading the lower portion of the corresponding motor bearing).

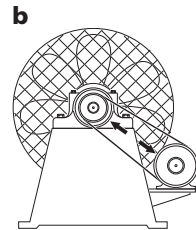
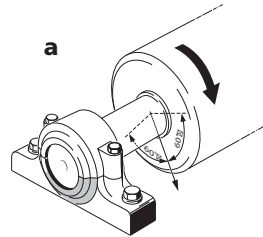

### 4. Locate the strongest signal

The location of the strongest signal within the load zone can be found using an ordinary vibration data collector.

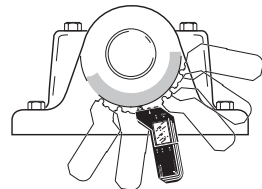

### C1. Coaxial cable connection to VIBREX

0. Remove the protective cap from the appropriate cable terminal on the VIBREX housing.
1. Pass the cable from the transducer through a suitable fitting into the housing. Note the assignment of the connection terminal to the module slot:
  - Sensor 1 = Left-hand module
  - Sensor 2 = Right-hand module

For combined vibration and bearing monitoring in one-channel mode, connect the sensor to the roller bearing module (SENSOR 1 terminal).



**Note**

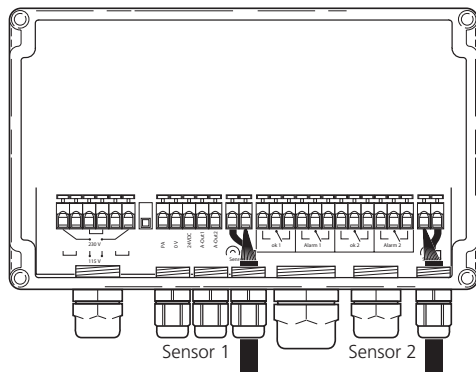

2. Strip the cable insulation and clamp core cable ends on the inner core and on the outer shield.
3. Connect the cable to the 'Sensor 1' or 'Sensor 2' terminal pairs, respectively.

Use a small screwdriver to firmly depress the white tab until the terminal opens far enough to allow insertion of the cable conductor, then release the tab to clamp the conductor into place.

The terminal to which the signal and shield wires should be connected can be identified by the symbols below the terminal.

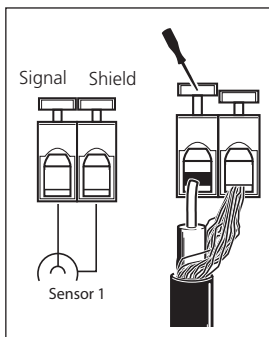

**C2. -- Content has been deleted**



### C3.1 Sensor connection with triaxial cable and sensor intermediate connector, VIB 6.770/13

#### Overview

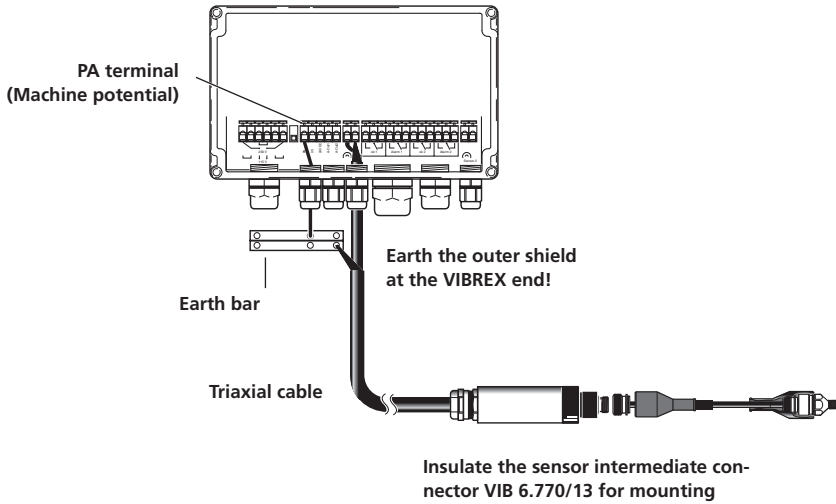

#### Note

If the sensor intermediate connector cannot be insulated for mounting, the outer shield of the triaxial cable must be reliably insulated at the intermediate connector end.

### Connecting the triaxial cable on the sensor intermediate connector

1. Open the housing of the intermediate connector.
2. Unscrew the threaded fitting and insert the triax cable.
3. Insert the outer shield into the threaded fitting.
4. Remove the insulation of the signal cable and the inner shield.
5. Connect the signal cable to the white wire and the inner shield to the blue wire.

For safety, measure the resistance between the signal socket at the TNC plug and the two connections in the intermediate connector. The connection at which the resistance is almost zero is connected to the signal cable.



**Note**

6. Screw up the intermediate connector and attach the threaded fitting again.

To prevent the signal transmission from being subject to interference, ensure that the sensor intermediate connector is electrically insulated before mounting.



**Note**

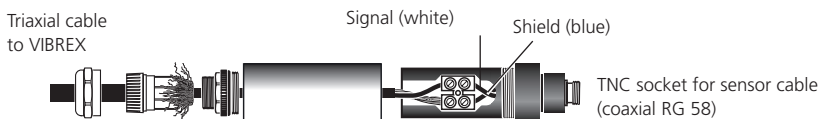

Connect the outer shield to the threaded fitting

**D. Warning and alarm outputs**

Errors such as open or short circuits or power outage are indicated for each module by an OK relay. The OK relay also activates when the signal level exceeds tolerance settings. When the error is resolved or the machine is operating within tolerance again, the OK relay returns to its original position following a switching delay of 3 to 4 seconds.

Alarms are issued for each module by an alarm relay. When the machine is operating within tolerance again, the alarm relay returns to its original position following a switching delay of 3 to 4 seconds.

- When making signal lead connections, ensure that
- the OK relay drops down when a warning or error is issued (NC) and
  - the alarm relay lifts up when an alarm is issued (NO).

NC: normally closed  
NO: normally open

	Normal condition	Warning / Error
OK Relay		
		Alarm
Alarm Relay		

Connection terminals for alarm ('Alarm1' = left-hand module) and warning/error ('OK1' = left-hand module)

**Note**

Signal sensor on OK relay  
Connect to terminals C and NC ('Normally Closed').  
When a warning or error condition (open circuit, short circuit) is detected, the OK relay activates NC so that the connected notification lamp or buzzer is activated.

Signal sensor on alarm relay  
Connect to terminals C and NO ('Normally Open').

### E. Analog current output (4-20 mA)

Left-hand module: Connect the current output to terminals 0V and A-Out1.

Right-hand module: Connect the current output to terminals 0V and A-Out2.

Valid burden resistor for tapping signal: 0 .. 500 ohm.

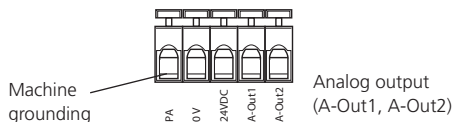

The two outputs have a permanent internal power supply. The 24VDC terminal is intended solely for supplying power to the VIBREX unit (see below). NEVER connect an external power supply to the 4-20mA evaluation unit.

Current level falls to 0 mA if the sensor circuit is open.  
 Bearing module: convert output current level to corresponding dBsv values as directed on page 36.  
 Ground VIBREX with the machine (terminal PA) in order to avoid current loops in the signal leads.



Note

**F. Power supply**

Mains connection (230 V): Connect the mains leads to terminals 1 and 6. Use a wire jumper to connect terminals 3 and 4 to each other.

Mains connection (115 V): Connect the mains leads to terminals 3 and 4. Use wire jumpers to connect terminals 1 and 2 and terminals 5 and 6 with each other.

DC supply (24 V): Connect the DC supply to terminals 24VDC and 0V.

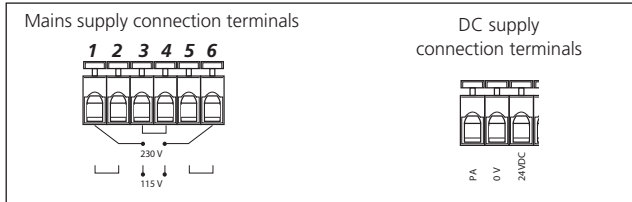
**G. Final check**

Check the connections and remount the cover.



## A. Vibration module adjustment

Vibration module settings can best be understood from an actual example as explained below.

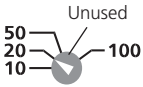
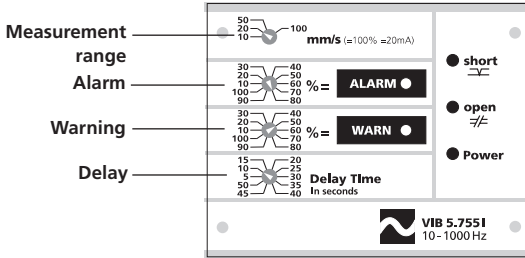

The position setting between the range limit values of '50' and '100' is unused: The pointer switch must never be set to this position!

### Measurement range

Use a small screwdriver to turn the upper pointer switch to the desired range limit value. This value indicates the highest signal level for the 4-20mA output signal (4mA output level always corresponds to 0 mm/s). This range limit should be set to barely exceed the proper alarm limit.

For example: If the alarm limit = 7 mm/s (according to ISO), then set the measurement range limit to 10 mm/s (for 20mA).

A signal level of XmA on the analog output, thus, corresponds to a vibration speed of Y mm/s

$$(XmA-4mA)/(20mA-4mA) * \text{Final value mm/s} = Y \text{ mm/s}$$

If a signal level of 9 mA is then measured, that would indicate an RMS vibration severity of

$$(9-4)/(20-4) * 10 \text{ mm/s} = \underline{3 \text{ mm/s}}$$

### Alarm limit, warning limit

Use the 'ALARM' and 'WARN' pointer switches to set the alarm and warning thresholds separately, each as a percentage of the measurement range limit.

Example: Assume measurement range = 10 mm/s

For alarm limit: 7 mm/s

ALARM = 70% (7 mm/s ÷ 10 mm/s = 70%)

For warning limit: 3 mm/s

WARN = 30% (3 mm/s ÷ 10 mm/s = 30%)

The OK relay normally issues messages for both warnings and sensor errors (including power outage). If, however, this relay is to be used only for system monitoring, set the warning value higher than the alarm value. The relay then can no longer trigger warnings, but reacts only to sensor faults and power outage.



**Note**

### Delay

Use the 'Delay Time' pointer switch to set the delay for alarm/warning output. (This does not affect the behavior of the indicator LED's, which always react to warning/alarm conditions after 1 to 2 s.) This delay should normally be set to exceed the duration of machine startup, since the machine can be expected to pass through transient vibration modes which could otherwise trigger false alarms.

Enter these settings into the measurement record (sample on p. 45) and place the folded record inside the housing.

## B. Gearboxes and low-speed machines

These machines require a reference measurement as the basis for setting alarm and warning limits. In addition to the machine manufacturer's guidelines and your own experience, this measurement helps to indicate machine operating condition. You can then use the ISO table on page 29 to add to this reference reading the appropriate intervals for alarm and warning limits.

You may use either a suitable measurement instrument to take this reading or you can measure the reference value via manual adjustment of the module. This second method is illustrated by the following example of manual setting with

the 'ALARM' pointer switch. The behavior of the indicator LEDs remains unaffected by the delay setting; they always react to warning/alarm conditions within 1 to 2 seconds.

\*This method may be also be used on standard machines to verify their operating condition.



Note

### Reference measurement\*

1. Switch on the machine and connect the power supply.

When no error conditions are detected, only the green 'Power' LED illuminates in the right-hand row of LEDs. (Troubleshooting: see page 37.)

2. Use a small screwdriver to set the measurement range limit (a) to 10 mm/s and the 'ALARM' pointer switch (b) to 30%. The 'ALARM' LED illuminates.
3. Increase the 'ALARM' setting step by step until the 'ALARM' LED goes out. Wait several seconds for the system to react after each turn of the pointer switch.
4. If the 'ALARM' LED continues to glow even with its limit switch set to 100%, then increase the measurement range limit by one notch and repeat the procedure.

The accuracy of this method depends upon the particular interval within which the measurement value lies.

Measurement value between	Resolution
50 mm/s and 100 mm/s	10 mm/s
20 mm/s and 50 mm/s	5 mm/s
10 mm/s and 20 mm/s	2 mm/s
0 mm/s and 10 mm/s	1 mm/s

5. Repeat this reference measurement several times in order to reduce the effects of measurement fluctuations. If necessary, you may want to vary the individual machine operating parameters such as RPM, load, volume rate etc. in order to simulate actual operating fluctuations that can be expected during production.
6. Once determined through this series of measurements, enter the reference value into the measurement record (see appendix) and place the folded record inside the housing.

## Anti-friction bearing monitoring

Evaluation and monitoring of bearing condition are performed through use of the shock pulse method. The characteristic parameters used with this technique are carpet value and maximum value. VIBREX monitors the maximum value, which is indicative of bearing damage.



A reference measurement is required as a basis for setting alarm and warning limits. This measurement indicates the current bearing condition.

You may use either a suitable measurement instrument to take this reading or you can determine the reference value via manual adjustment on the module. This second method is illustrated by the following example of manual setting with the 'ALARM' pointer switch. The LED's operate independently of delay settings and react in approx. 1 - 2 seconds.

### Reference measurement

1. Switch on the machine and connect VIBREX to its power supply. When no error conditions are detected, only the green 'Power' LED illuminates in the right-hand row of LEDs. (Troubleshooting: see page 37.)
2. Set the alarm limit to 50 dBsv. Use a small screwdriver to turn the upper pointer switch (a) to '50' and the middle pointer switch (b) to '0'.
- 3a. If the 'ALARM' LED illuminates, the proper value is greater than 50 dBsv. In that case, increase the setting step by step until the LED goes out.
- 3b. If the 'ALARM' LED does not illuminate, then reduce the alarm value step by step until the LED illuminates.

Wait several seconds for the system to react after each turn of the pointer switch. The setting at which the LED lights or goes out corresponds to the correct reference value.



**Note**

4. Repeat this reference measurement several times in order to reduce fluctuation effects. Vary the individual machine parameters such as RPM, load, volume rate etc. to simulate actual operating fluctuations.
5. Enter the reference value into the measurement record and place the folded record inside the housing.

**Bearing module adjustment**

1. Use a small screwdriver to set the alarm limit with the two upper pointer switches. The warning limit is permanently fixed at 15 dB below the alarm limit setting.

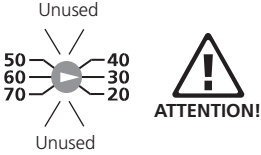

The position settings between the range limit values of '40' and '50' and between '20' and '70' are unused: The pointer switch must never be set to these positions!

With reference measurement:  
 If the bearing is new or known to be in good condition, the alarm limit should be set 35 dBsv above the measured reference level.  
 For older bearings or those whose condition is not known with certainty to be good, the alarm limit should be set only 25 dBsv above the measured reference level.

Without reference measurement: If reference measurement is not possible, use the following nomogram to determine the proper alarm limit setting:

Example:  
 If  
 Bore diameter = 100 mm  
 Rotation speed = 1000 RPM  
 then  
 Alarm limit = 53 dB<sub>sv</sub>

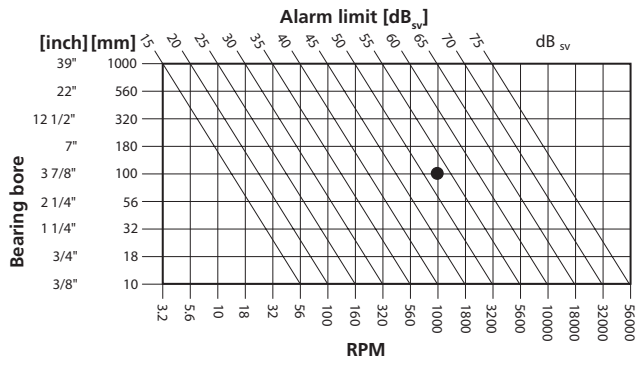

**Note**

This nomogram is intended only as an orientation aid in setting alarm limits for standard machines. Adjustment may be necessary, for example depending upon different bearing types, static and dynamic loading or signal damping.

2. Use the 'Delay Time' pointer switch to set the delay for alarm/warning output.
3. Enter the settings into the measurement record (see sample on page 43); make a note as well whether the OK relay is set only for self-diagnosis or for issuing signal level warnings as well (see page 11 for details). Place the folded record inside the housing.

The procedures described in this manual regarding warning and alarm tolerance settings apply, in their experience, to the vast majority of machines. In special cases, however, alternative setting values may be required; PRÜFTECHNIK cannot assume responsibility for the accuracy of such values.



**Note**

### Conversion of output current level [mA] to shock pulse value [dBsv]

mA	4	5	6	7	8	10	12	14	16	18	20
Y	0	0	2	5	8	11	14	16	18	19	20

$$\text{dBsv} = Y + (\text{Alarm limit}) - 20$$

Shock pulse value dBsv = Y plus alarm limit setting minus 20

Example

Alarm setting: 50 dBsv

Current level: 10 mA => Y = 11

Shock pulse value:  $11 + 50 - 20 = 41 \text{ dBsv}$



Note

- The current level falls to 0 mA when the sensor circuit is open.
  - The shock pulse value is 0dBsv for I = 4mA.
  - The shock pulse value is 1dBsv for I = 5mA if the alarm value is set lower than 25 dB.
- For alarm values that are set higher, the following formula applies:  $\text{dBsv} = -24 + \text{alarm value}$ .

The complete formula for calculating the shock pulse level is:

$$\text{dBsv} = \text{alarm level} + 20 * \log((\text{current}-4\text{mA})/16\text{mA})$$

## External signal measurement

A bulkhead connector (e.g. VIB 93036F) allows quick and convenient direct connection to a hand-held measurement/display instrument such as VIBROTIP

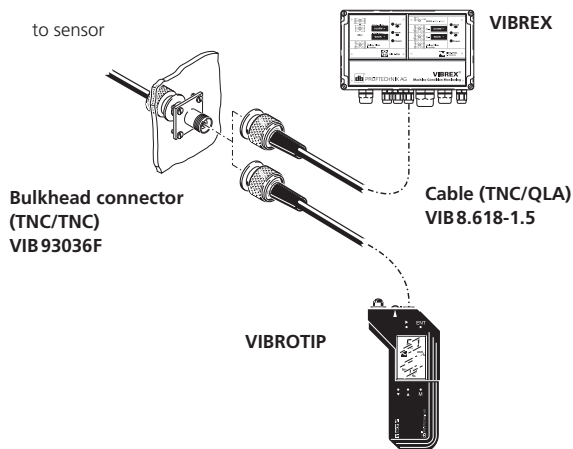

Use of the bulkhead connector VIB 93036S (threaded connection, TNC/TNC) or VIB 93036F (flanged connection) requires an additional cable (2 x TNC).

The bulkhead connector must be mounted electrically insulated.

VIBROTIP can measure only signals that are processed by the standard vibration and bearing modules (VIB 5-7xxI).

Gearboxes and low-speed machines (module versions G and L): PRÜFTECHNIK measuring instruments (VIB-SCANNER or VIBXPERT) or the measuring instruments of other manufacturers can be used. For these instruments, the adapter for the current pre amplifier (VIB 8.749) can be used to convert the sensor current signal into a voltage signal.

If the VIBREX and measuring instrument have different frequency ranges, the measured values of the two instruments are not comparable.



**Note**



## Troubleshooting

Be sure to disconnect the power supply before opening the housing for troubleshooting!



**Symptom:** 'Power' LED does not illuminate upon connection with power supply.

**Cause 1:** Faulty power supply connection.

**Remedy:** Check the connection; reconnect if necessary.

**Cause 2:** Fine fuse burned out on mother board.

**Remedy:** Replace the resistance fuse (standard fine-wire fuse, 160 mA, slow-acting). The left module must be removed in order to do so (page 38).

Fine-wire fuse  
(160 mA, slow-acting)

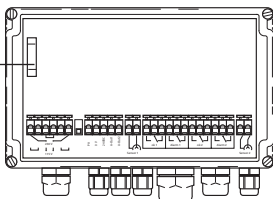

**Symptom:** 'Open circuit' LED illuminates

**Cause:** The signal path to the sensor is interrupted.

**Remedy:** Check for loose connections to the sensor and the terminals inside the VIBREX housing.

**Symptom:** 'Short circuit' LED illuminated.

**Cause:** Sensor or cable is short circuited.

**Remedy:** Check the cable and replace it if necessary. Check the sensor connection for looseness or improper fastening.

**Symptom:** 'ALARM' LED does not illuminate during reference measurement.

**Cause 1:** The signal path to the sensor is interrupted.

**Remedy:** Check connections on the sensor and the terminals inside the VIBREX housing.

**Cause 2:** The machine is switched off or is running extremely smoothly.

**Symptom:** 'WARN' LED on bearing module illuminates following alarm limit adjustment.

**Cause:** Wear or initial damage to bearing or insufficient lubrication.

**Remedy:** Do not change alarm limit setting, but observe measurement levels closely as the bearing continues to run within the warning range.

### Changing modules

VIBREX is delivered with modules installed. If you should ever need to replace a module, proceed as follows:

1. Disconnect or turn off the power supply to VIBREX.
2. Remove the housing lid.
3. Remove all four mounting screws from the module.
4. Carefully remove the module from the housing.
5. Plug the replacement module onto the chassis.



Take care not to bend or damage the contact pins on the module.

6. Screw the module into place and replace the housing lid.

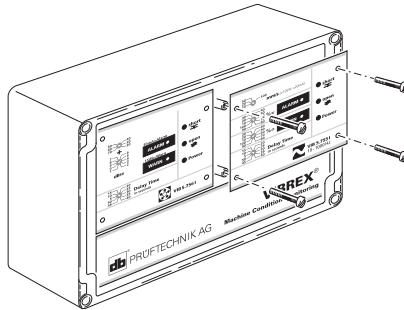

# Appendix

## Connection terminals

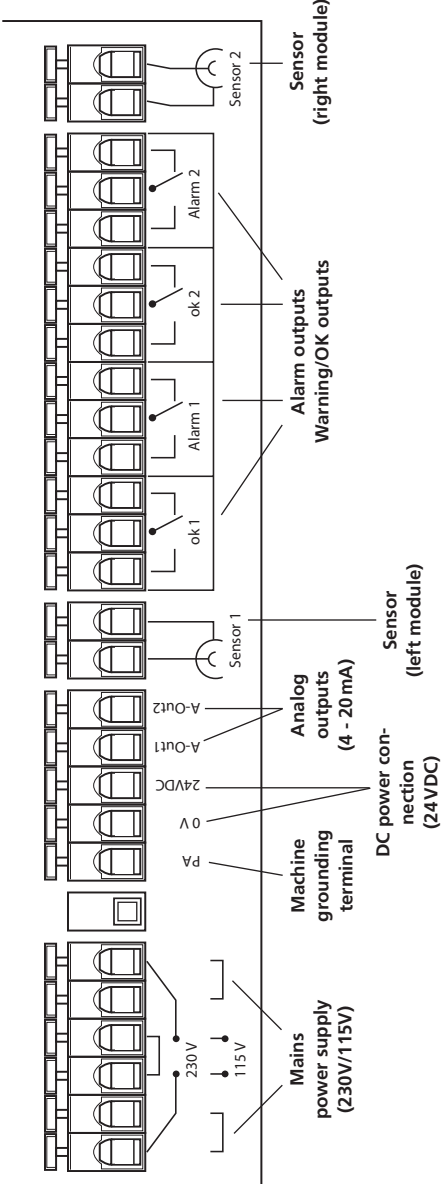

## Technical data

### VIBREX basic unit

Operating modes	Combined vibration/bearing monitoring (1 or 2 channels); Vibration/bearing monitoring alone (1 or 2 channels);
Slots	1 or 2 modules
Inputs	1 or 2 sensors; AC voltage; DC voltage
Outputs (per module)	1 alarm relay; 1 OK relay for warning/error indication 1 analog signal output (4-20 mA) 1 mV output
Max. switching power	3 A / 250 VAC
Cable connections	Threaded fittings into housing; internal cable connections via clamping levers
Power supply	AC: 115V/230V, 6 VA, 50/60 Hz switchable, or DC: 24V, <300 mA, 10-15% (IEC 93) AC, DC respect.
Overload protection	Thermal fuse in transf. and secondary-side resistance fuse (standard fine-wire 160 mA, slow-acting)
Temperature range	-10 °C to +60 °C / 14°F to 140°F
Housing	MacroLon with transparent lid, Protection class: II
Env. protection	IP 65 (water spray- and dustproof)
Vibration limit	50 ms <sup>-2</sup> (median frequency 60 Hz; bandwidth 100 Hz)
Dimensions, WxHxD	200 mm x 120 mm x 77 mm 7 7/8" x 4 3/4" x 9 5/8"
Intr. safety	optional, with safety barrier and intrinsically safe sensors
Signal diagnosis	via mV output (optional)
Specification for mV output:	
Output	Direct sensor signal (buffered, 100 Ohm)
Transmission	1.0 mV <sub>eff</sub> /ms <sup>-2</sup> (= 10 mV/g) Standard transducer (Sensitivity: 1 µA/ms <sup>-2</sup> ) 5.35 mV <sub>eff</sub> /ms <sup>-2</sup> (= 52 mV/g) Transducer for 'low-speed machines' (Sensitivity: 5.35 µA/ms <sup>-2</sup> ) 10.2 mV <sub>eff</sub> /ms <sup>-2</sup> (= 100 mV/g); ICP-type transducer
Frequency response	corresponds to transducer



### Anti-friction bearing module VIB 5.756 I

Parameter	Shock pulse [dB <sub>sv</sub> ] for anti-friction bearing evaluation
Meas. range	20 to 79 dB <sub>sv</sub> adjustable in steps of 1 dB <sub>sv</sub>
Sensor	Accelerometer (standard), sensitivity: 1.00 µA/ms <sup>-2</sup>
Alarm/warning output	Alarm limit adjustable from 20 to 79 dB <sub>sv</sub> (1 dB <sub>sv</sub> steps) warning limit fixed at 15 dB <sub>sv</sub> below alarm limit setting
Alarm/warning delay time	Adjustable from 5 s to 50 s in steps of 5 s
Display	5 LEDs: for indication of alarm, warning, short circuit, open circuit and power
Analog signal output	4 to 20 mA (delivered by basic unit)
Operating voltage	18 to 30 VDC
Max. current	approx. 35 mA

Special versions available upon request.

**Vibration module VIB 5.755 ...**

Parameter	Vibration velocity (RMS)
Frequency range	
VIB 5.755 I	10 Hz - 1 kHz (ISO/RMS value)
VIB 5.755 L	1 Hz - 1 kHz ('low-speed', > 60 RPM)
VIB 5.755 ML	2 Hz - 1 kHz ('low-speed', > 120 RPM)
Meas. range	0 to 10, 20, 50, 100 mm/s , adjustable (Standard)
Sensor	Accelerometer (standard), sensitivity: 1.00 $\mu\text{A}/\text{ms}^{-2}$ Accelerometer for low-speed, sensitivity: 5.35 $\mu\text{A}/\text{ms}^{-2}$
Alarm/warning output	Alarm and warning limits adjustable as percentage of total range in steps of 10%
Alarm/warning delay time	adjustable from 5 to 50s in steps of 5s
Display	5 LEDs: for indication of alarm, warning, short circuit, open circuit and power
Analog signal output	4 to 20 mA (delivered by basic unit)
Operating voltage	18 to 30VDC
Max. current	approx. 35 mA

**Acceleration module VIB 5.757 G**

Parameter	Vibration acceleration (RMS)
Frequency range	
VIB 5.757 G	2 Hz - 20 kHz (ISO/RMS value)
Meas. range	0 to 60, 120, 300, 600 $\text{m}/\text{s}^2$ , adjustable
Sensor	Accelerometer (standard), sensitivity: 1.00 $\mu\text{A}/\text{ms}^{-2}$
Alarm/warning output	Alarm and warning limits adjustable as percentage of total range in steps of 10%
Alarm/warning delay time	Standard: adjustable from 5 to 50s in steps of 5s
Display	5 LEDs: for indication of alarm, warning, short circuit, open circuit and power
Analog signal output	4 to 20 mA (delivered by basic unit)
Operating voltage	18 to 30VDC
Max. current	approx. 35 mA



**Dimensions**

(in mm)

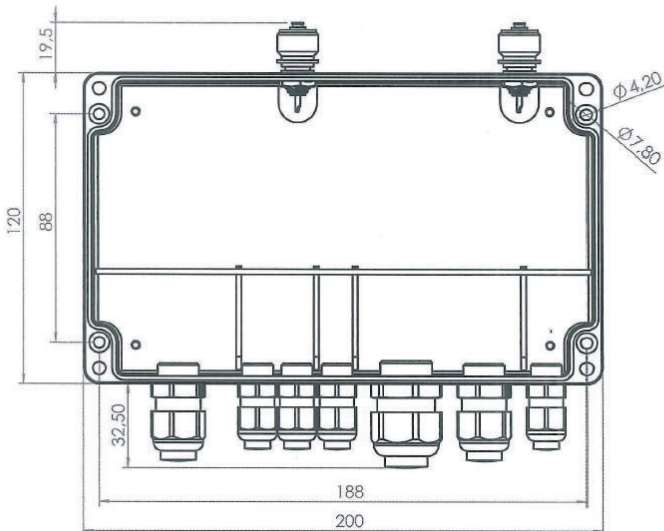
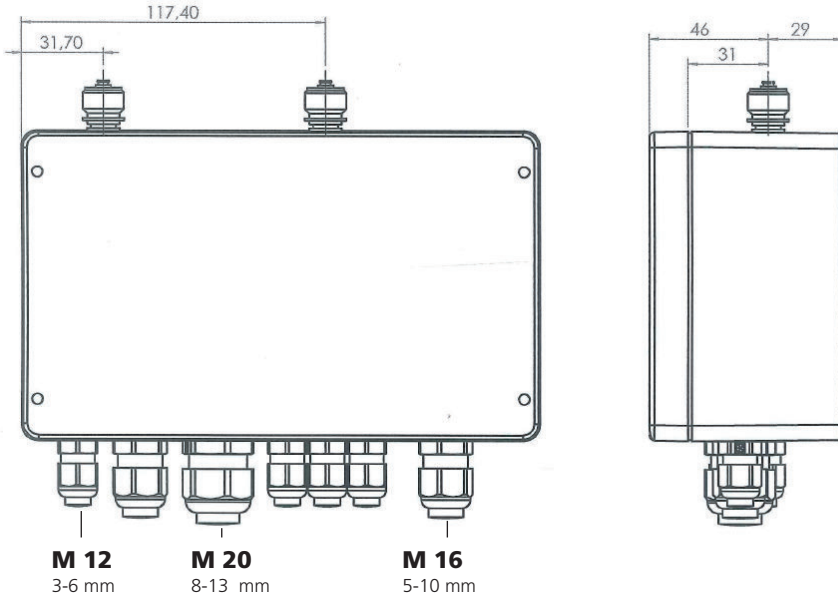

## Measurement record

The two forms printed below are designed to help you record and document module settings and reference measurement values. They allow you to restore the modules to their original settings in case they should ever accidentally become misadjusted.

1. Make a photocopy of these forms and cut them out.
2. After module adjustment, fill out the forms.
3. These forms can be placed inside the VIBREX housing before closing its lid or kept at hand elsewhere.

	
<b>Bearing module</b>	
Reference:	[dBsv]
Alarm:	[dBsv]
Delay:	[s]
OK relay:	OK/WARN      OK
Date:	
Signature:	

	
<b>Vibration module* / Acceleration module</b>	
Reference:	[%]      [mm/s] / [m/s <sup>2</sup> ]
$v_{max.} / a_{max.}$ :	[mm/s] / [m/s <sup>2</sup> ]
Alarm:	[%]      [mm/s] / [m/s <sup>2</sup> ]
Warning:	[%]      [mm/s] / [m/s <sup>2</sup> ]
Delay:	[s]      [ms]
Date:	
Signature:	

\* delete which is inapplicable

**VIBREX delivery packages**

Content has been deleted.

Please refer to the VIBREX catalog for details about delivery packages.

**Content has been deleted**

Please refer to the VIBREX catalog for details about delivery packages.



## **VIBREX modules: Application examples**

### **VIB 5.755 I**

Frequency range: 10 Hz - 1 kHz

Measurement range: 100 mm/s

Parameter: Vibration velocity (RMS)

Transducer\*: VIB 6.122R ( $1 \mu\text{A}/\text{ms}^{-2}$ )

Application example: Vibration monitoring on high-speed machines (>600 RPM) according to ISO 10816-3.

Note: This module can be combined with the bearing module VIB 5.756 I in 1-channel monitoring as a 'Slave' since both modules use the same type of sensors.

### **VIB 5.755 L**

Frequency range: 1 Hz - 1 kHz

Measurement range: 100 mm/s

Parameter: Vibration velocity (RMS)

Transducer\*: VIB 6.127 ( $5.35 \mu\text{A}/\text{ms}^{-2}$ )

Application example: Vibration monitoring on very low-speed machines such as cooling tower fans, mixers, stirrers,..

Note: This module cannot be combined with the bearing module VIB 5.756 I in 1-channel monitoring as a 'Slave' since both modules use different types of sensors.

### **VIB 5.755 ML**

Frequency range: 2 Hz - 1 kHz

Measurement range: 100 mm/s

Parameter: Vibration velocity (RMS)

Transducer\*: VIB 6.122R ( $1 \mu\text{A}/\text{ms}^{-2}$ )

Application example: Vibration monitoring on medium-speed and low-speed machines (>120 RPM) according to ISO 10816-3.

Note: This module can be combined with the bearing module VIB 5.756 I in 1-channel monitoring as a 'Slave' since both modules use the same type of sensors.

**VIB 5.756 I**

Measurement range: 79 dB<sub>sv</sub>  
Parameter: shock pulse [dB<sub>sv</sub>]  
Transducer\*: VIB 6.122R (1 μA/ms<sup>-2</sup>)



Application example: Bearing monitoring using the shock pulse method.

**VIB 5.757 G**

Frequency range: 2 Hz - 20 kHz  
Measurement range: 600 m/s<sup>2</sup>  
Parameter: Vibration acceleration (RMS)  
Transducer\*: VIB 6.122R (1 μA/ms<sup>-2</sup>)



Application example: Condition monitoring of high-speed gearboxes (turbo gearboxes, compressors).

The acceleration module can be combined with the bearing module VIB 5.756 I in 1-channel monitoring as a 'Slave' since both module series use the same type of sensors.







**Faithful companion**

VIBSCANNER® is the ideal partner for your daily measuring and inspection rounds. Integrated transducers record all important machine signals. Process parameters can be supplied as analog signals or entered manually. A checklist of visual inspection tasks, e.g. 'Check oil level', assists in tracing faults. FFT and balancing is also included. Graphic user guidance and intuitive joystick navigation make operating child's play.

VIBSCANNER® – Machine evaluation, data collection & balancing



**Machine vibration**  
**Bearing condition**

**Condition monitoring made feasible**

Economical modular components and simple installation make condition monitoring with VIBREX® feasible even for smaller production aggregates. Alarm-activated switching via PLC and direct mA signal output allow machine control and measurement trending by external systems.

VIBREX®: On-site monitoring and control for 1 or 2 locations



**wwwatch me now**

VIBRONET® Signalmaster lets you monitor and analyze your machine condition from around the globe. It is the first telediagnosis system in the world to take advantage of Internet technology for communication and data transmission. When the situation at hand demands immediate attention, the Signalmaster instantly notifies the specialists by eMail or SMS.

VIBRONET® Signalmaster: Telediagnosis via Internet & mobile phone

Fluke Deutschland GmbH  
 Freisinger Str. 34,  
 85737 Ismaning, Germany  
 + 49 89 99616-0  
 www.pruftechnik.com