



CAT-IV

# ISO 18436 Category IV

## Master Vibration Analyst Training & Certification

### Hybrid Public Course and Online Training

Learn vibration analysis from the world's leading provider of training & certification. At Mobius Institute, we offer the most understandable and interesting training available. Our Crystal Clear™ training methodology is unique, using hundreds of 3D animations and software simulations that make complex concepts easier to understand. We offer ISO 18436 Category I to IV training via public venue courses as well as online through the Mobius Institute website.

Mobius Institute is ISO/IEC 17024 and ISO 18436-1 accredited, meaning that you are assured that your certification meets the highest global standards, and our training teaches you everything you need to know according to the ISO 18436 standard for vibration analyst training. There is no more highly regarded training & certification available.

ATO LOGO HERE



# CAT-IV Course Overview

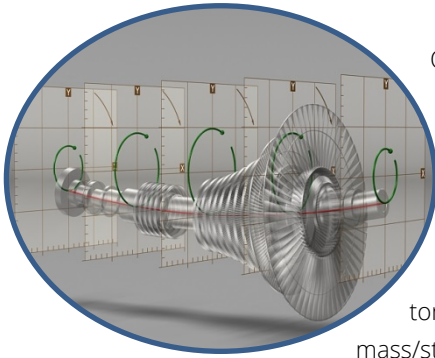

Our Category-IV Master course is a hybrid format that meets the ISO 18436-1 and ISO 18436-2 requirements while allowing you to complete the first half (Part 1) of the course through online learning via the web. The second half (Part 2) of the course is delivered in a live classroom setting where you complete your training and optionally take the Category IV certification examination.

You will learn advanced measurement signal processing techniques, including torsional vibration and cross-channel measurements, dynamics including mass/stiffness/damping and natural frequencies, modal analysis and operating deflection shapes, orbit and centerline analysis, rotor dynamics, correction techniques including isolation, damping, and tuned absorbers, and other advanced topics. Upon completing the course, you will be qualified to lead condition monitoring teams and will have a deep understanding of machine dynamics and failure modes. With your knowledge and qualifications you are able to design tests to solve difficult problems and identify underlying issues to prevent recurrence. You will carry the highest regard in the field of machine condition monitoring.

Mobius vibration analysis training is unique. We use 3D animations, Flash simulations, and numerous software simulators that completely demystify vibration analysis. While vibration training courses have traditionally been very theoretical, difficult to understand, (and boring), you will be captivated by the Mobius training methods, and you will enjoy our practical approach. You will take away skills that you can immediately apply to your job, and you will truly understand what you are doing.

You will leave the course with a solid understanding of:

- Advanced signal processing
- Cross channel measurements
- Machine Dynamics
  - Mass/stiffness/damping
  - Natural frequencies / modes
- Rotor / bearing dynamics
- Resonance testing
  - Run-up/coast down tests
  - Impact tests
  - ODS
  - Modal analysis
- Corrective action
  - Flow control
  - Resonance correction
  - Isolation
  - Damping

This course takes a practical approach to these subjects. Animations and software simulations are used to make these topics easier to understand. Mathematics and theoretical derivations will be kept to an absolute minimum.

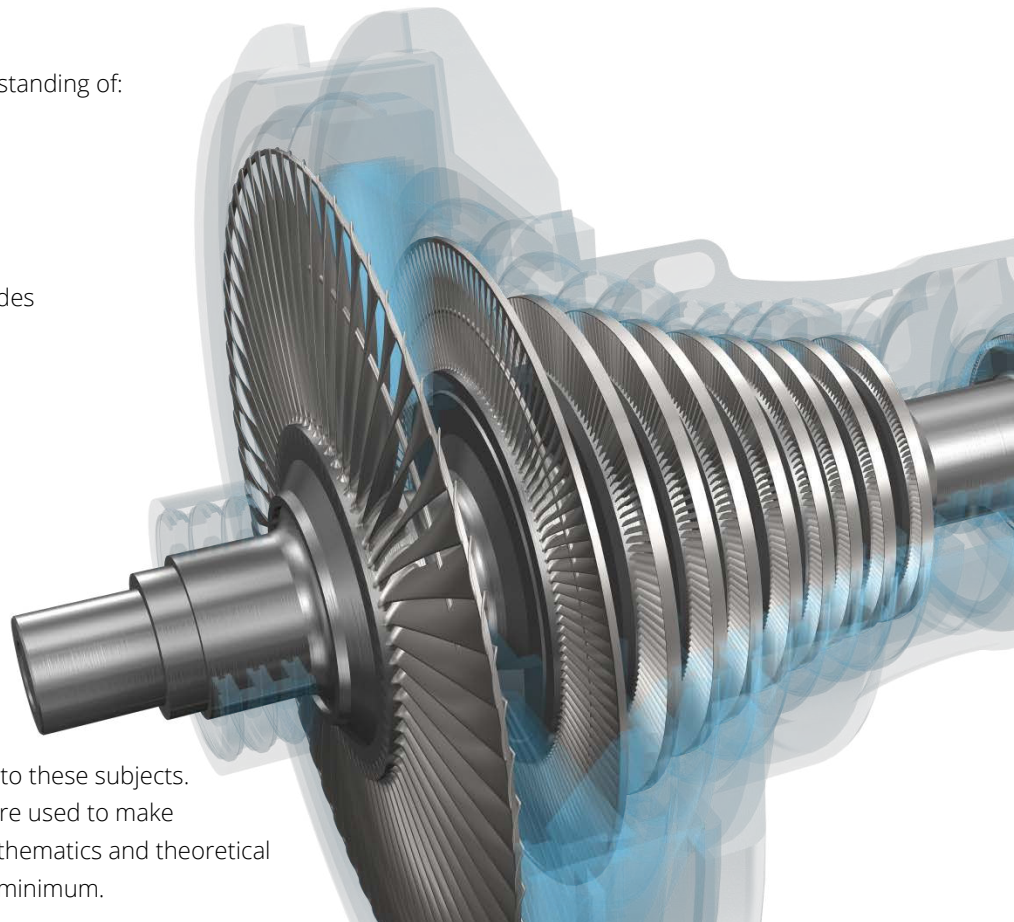

Our public courses are conducted by an experienced, certified Mobius Institute instructor at Mobius Institute authorized training centers in 50 countries throughout the world. See the Mobius institute website at [www.mobiusinstitute.com](http://www.mobiusinstitute.com) to see the courses scheduled in your area. All of our training courses are also offered at your site, so if you have several people to train, we can come to your location.

# CAT-IV Course **Description**

**Duration:** 8 days

**Format:** 4 days (equivalent) online learning via the web & 4 days at a public course venue.

**Optional:** 1 day review & certification examination, 70% passing grade

**Compliance:** ISO 18436 Category IV – Vibration Analyst

**Public Course Prerequisite:** The online portion (Part 1) of the course must be completed before you may attend the classroom portion of the course (Part 2)

**Online Learning:** Registered students are given access to the Mobius Institute Learning Management System for a period of 6 months to provide ample time to learn the material and prepare for the public course (purchased & scheduled separately)

**Certification Prerequisite:** Prior experience is not required for attending the training course, but you must have 60 months of verifiable experience and Category III certification by an accredited certification body to qualify for Category IV exam and certification.

**Outcome:** You will come away from this course qualified to lead condition monitoring teams and will have a deep understanding of machine dynamics and failure modes.

## \*\*\*Category IV - Candidate Profile:

- You have at least five years of vibration analysis experience
- You want to be a leader of the vibration team, or take a leading role in diagnosing faults and making repair recommendations
- You want to understand all data collector options, special test capabilities, all analysis tools and understand the widest range of fault conditions
- You are seeking to become certified to international standards (ISO-18436) by an accredited certification body
- You want to understand all condition monitoring technologies, how and when to apply them
- You want to understand machine dynamics (natural frequencies, resonance, ODS), how to perform resonance testing and how to correct resonance problems

## Topics covered:

- Review of condition monitoring technologies and the ISO standards
- Signal processing and data acquisition
- Time waveform analysis
- Phase analysis
- Dynamics (natural frequencies and resonance)
- Testing for natural frequencies
- Operating Deflection Shape (ODS) analysis
- Modal analysis and intro to FEA
- Correcting resonances
- Rolling element bearing fault detection
- Journal bearing fault detection
- Electric motor testing
- Pumps, fans and compressors
- Gearbox fault detection
- Corrective action
- Running a successful condition monitoring program
- Acceptance testing
- Review of ISO standards



The purchase of the **public course** includes a complimentary copy of Robert Eisenmann's book (in PDF format); "*Machinery Malfunction Diagnosis and Correction*". The book examines the technology of analyzing process machinery malfunctions. It begins with fundamental concepts of mechanical motion, and expands the basic models into acceptable simulations of real machines. Relationships between the actual machinery, the analytical model, and the vibration characteristics are examined. Specifically, steam and gas turbines, gear boxes, centrifugal and reciprocating compressors, plus motors and generators are analyzed from different perspectives. It is extensively illustrated, and it contains detailed examples with sample calculations. The book also includes 45 case histories that cover the entire scenario from problem definition, through investigation, plus the final corrective solutions.

## CAT-IV Certification

All Mobius certified analysts receive personalized logos with their certification number and name for their own professional use. Mobius Institute also maintains a listing of all certified analysts on our website and provides each analyst with a certification confirmation webpage.

For more information about Mobius Institute's accreditation, and the recognition of your certification by the ISO 18436 standard, please visit [www.mobiusinstitute.com/certification](http://www.mobiusinstitute.com/certification).

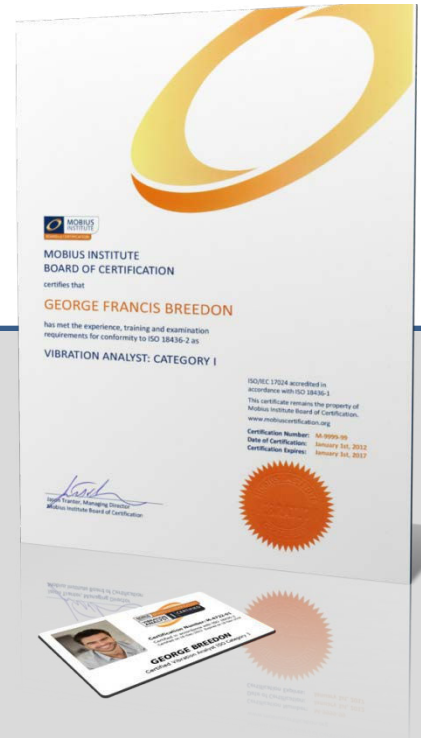

## Get started today

Go to our website to learn more about our public and online learning courses, view the public course schedule for your area. Don't hesitate to mail your questions to [learn@mobiusinstitute.com](mailto:learn@mobiusinstitute.com) or contact an authorized training center in your region.

### MOBIUS INSTITUTE

AUSTRALIA – BELGIUM – COSTA RICA – UNITED STATES  
and authorized training centers in 50 countries.  
CONTACT: [learn@mobiusinstitute.com](mailto:learn@mobiusinstitute.com)

[www.mobiusinstitute.com](http://www.mobiusinstitute.com)

© 2015 – Mobius Institute – All rights reserved.

